



Compact oval cylinder with adjustable pneumatic cushioning and standard magnetic version; its special shape allows the assembly of several coupled cylinders with reduced overall dimensions (in width).

TECHNICAL CHARACTERISTICS

Working pressure: 1,5 ÷ 10 bar
 Ambient temperature: -20°C ÷ 80°C
 Fluid: compressed air, lubricated or not.
 Barrel: extruded barrel in aluminium alloy, anodized externally and internally 15 µm with profile for flush-mounted sensor
 End-caps in aluminium.
 Self-threading screw in zinc-plated steel.
 Piston in aluminium.
 Piston seals in nitrile rubber.
 Rod seals in polyurethane.
 Adjustable pneumatic cushioning which allows an efficient

deceleration of the piston and reduces noise level.
 Piston rod in chromium-plated steel Ø 32 ÷ 80 mm, in stainless steel Ø 18 ÷ 25 mm.
 Magnetic version.
 Max. speed: 1 m/s
 With integrated fixing accessories: front, rear, lower and side.

Executions upon request:

- Versions with stainless steel rod (Ø 32 ÷ 80 mm) or in chromium-plated steel (Ø 18 ÷ 25 mm)
- Magnetic sensor DF-...series.
- Wire cover strap for magnetic sensor part n° DHF-002100.

Theoretical forces (N) developed at the following working pressures (bar) 1

bar = 0,1 MPa

Cyl. Ø		Working pressure [bar]				
		2	4	6	8	10
18	Thrust	54	108	162	216	270
	Traction	41	82	122	163	204
25	Thrust	98	196	295	393	491
	Traction	82	165	247	330	412
32	Thrust	161	322	483	643	804
	Traction	138	276	415	553	691
40	Thrust	251	502	754	1005	1256
	Traction	221	422	633	844	1055
50	Thrust	393	785	1178	1570	1963
	Traction	330	660	990	1320	1650
63	Thrust	623	1246	1870	2493	3116
	Traction	560	1120	1682	2240	2800
80	Thrust	1005	2010	3015	4019	5024
	Traction	942	1884	2826	3770	4711

Maximum applicable torque (Nm) and respective max. rotation

Cyl Ø	Nm	(°)
18	0,80	0,90
25	1,00	0,80
32	1,40	0,60
40	1,70	0,40
50	2,00	0,35
63	2,30	0,30
80	2,60	0,30

In case of pneumatic cylinders with through rod, theoretical force to be considered, in both direction, is always the same as the "traction" value indicated in the table. In practice these values will have to be reduced taking into account the weight and sliding friction of moving parts (approx. ~ -10%).



Nominal tolerance on the stroke

Cyl Ø	Tolerance mm
18 ÷ 25	+ 1,5/0
32 ÷ 50	+ 2/0
63 ÷ 80	+ 2,5/0

Codification key

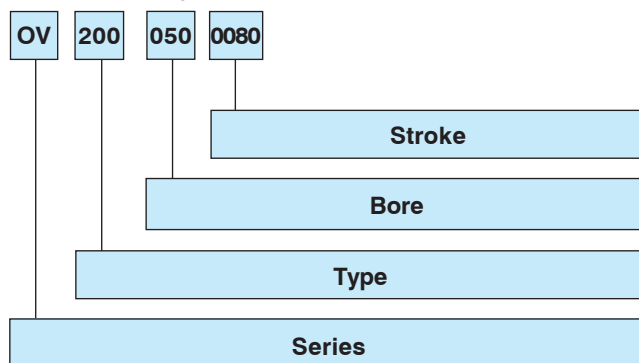

SERIES

OV = Oval Cylinders Ø 18 ÷ 80 mm

TYPE

- 1--- Female rod in stainless steel
- 2--- Female rod in chromium-plated steel (excluded Ø 18 - 25 mm)
- 3--- Male rod in stainless steel
- 4--- Male rod in chromium-plated steel (excluded Ø 18 - 25 mm)
- 00 D.A.
- 01 D.A. through rod
- 02 D.A. hollow through rod

BORE

018 - 025 - 032 - 040 - 050 - 063 - 080 mm

STROKE

0010-0025-0040-0050-0080-0100-0125-0160-0200 (Ø 18 ÷ 80 mm)
 0250-0320 (Ø 32 ÷ 80 mm)

Double-acting cylinders Ø 18 mm

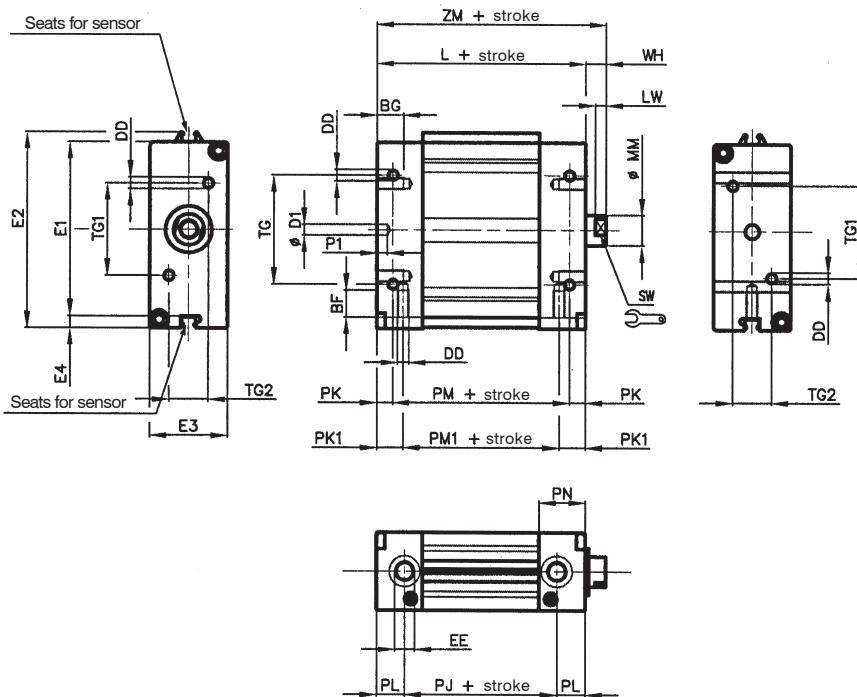

Female rod OV100.../OV200...series

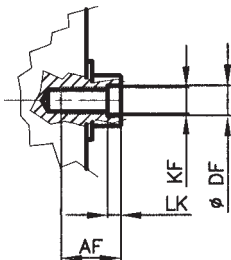

Male rod OV300.../OV400...series

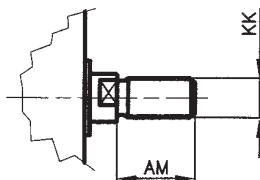

Cyl. Ø	AF min	AM	B f9	BF min	BG min	D1 H9	DD	DF	E1	E2	E3	EE	H1	L	KF	KK	LK
18	8	20		6	6	4	M4	4,1	40,5	50,5	16	M5		60	M4	M8	1
25	12	22	16	8	8	4	M4	5,1	52	57	20	M5		62	M5	M10X1,25	2
32	14	22	20	8	8	4	M5	6,2	61	66	24,5	G1/8	4,5	72	M6	M10X1,25	2,5
40	16	24	25	12	12	4	M5	8,2	61,5	67	38	G1/8	9	76	M8	M12X1,25	3
50	20	32	30	14	14	5	M8	10,5	76	81	40	G1/4	9,5	82	M10	M16X1,5	5
63	20	32	30	14	10,5	5	M10	10,5	92	97	50	G1/4	10,5	82	M10	M16X1,5	5
80	20	32	40	15	15	5	M10	10,5		130	60	G1/4	9	106	M10	M16X1,5	5

Double-acting cylinders Ø 25 ÷ 80 mm

Cyl. Ø 80 mm

Cyl. Ø 25 ÷ 63 mm

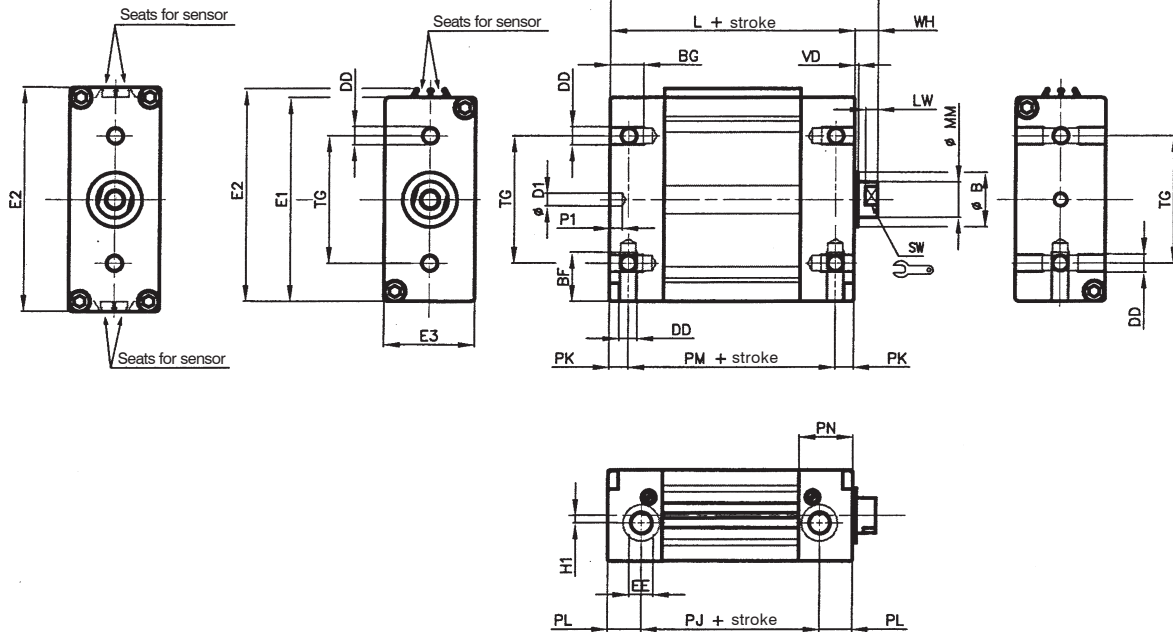

Mass

Cyl. Ø	Cylinder stroke "0" (g)	Increase per mm stroke (g)	Moving parts stroke "0" (g)	Increase per mm stroke (g)
18	120	1,3	30	0,4
25	180	1,8	60	0,6
32	290	2,4	105	0,9
40	465	3,4	165	1,6
50	780	4,7	230	2,5
63	1145	5,8	295	2,5
80	2245	8,6	535	2,5

NOTE: The cushioning length may vary in comparison with that indicated depending on the different application and operation.

Cyl. Ø	MM	P1	PJ	PK	PL	PM	PN	SW	TG	VD	WH	ZM	Cushioning length
18	8	7	44	4	8	52	16	7	20		7	67	8
25	10	7	38	4	12	54	16	8	32	2	8	70	10
32	12	7	57	5	7,5	62	18	10	36	2	8	80	10
40	16	7	47	7,5	14,5	61	22	13	40	2	9	85	14
50	20	7	41	8,5	20,5	65	30	17	50	2	10	92	Front. 11/Rear 14
63	20	7	41	8,5	20,5	65	30	17	60	2	10	92	Front. 11/Rear 14
80	20	7	66	9	20	88	30	17	75	3	12	118	Front. 20/Rear 27

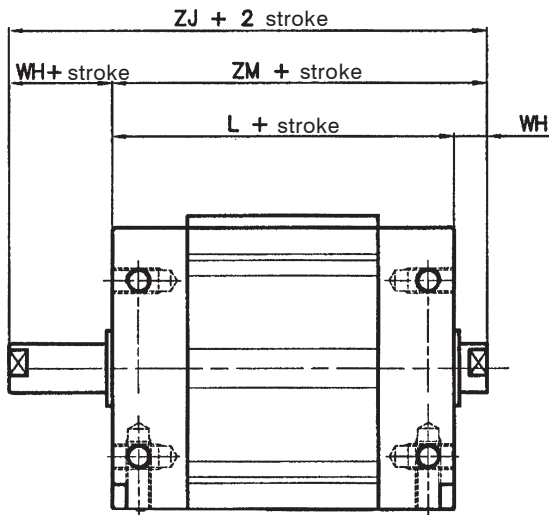

Mass

Cyl. \varnothing	Cylinder stroke "0" (g)	Increase per mm stroke (g)	Moving parts stroke "0" (g)	Increase per mm stroke (g)
18	140	1,7	50	0,8
25	210	2,4	90	1,2
32	330	3,2	140	1,8
40	535	5	235	3,2
50	900	7,2	350	5
63	1265	8,3	415	5
80	2390	11	680	5

NOTE: The cushioning length may vary in comparison with that indicated depending on the different application and operation. For lacking dimensions please refer to pages 4/5.

Female through rod

OV102.../OV202...series

$\varnothing 18 \div 25$ mm max stroke 100 mm

$\varnothing 32 \div 80$ mm max stroke 160 mm

Male through rod

OV302.../OV402...series

$\varnothing 18 \div 25$ mm max stroke 100 mm

$\varnothing 32 \div 80$ mm max stroke 160 mm

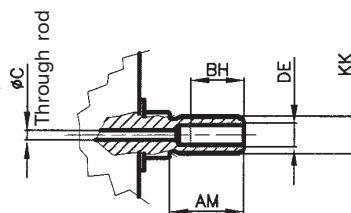
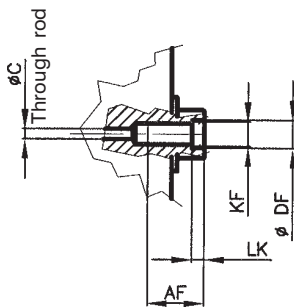

Cyl. \varnothing	AF min	AM	C min	DE	DF	KF	KK	L	LK	WH	ZM	ZJ	Cushioning length
18	8	20	1,5		4,1	M4	M8	60	1	7	67	74	8
25	12	22	2,5		5,1	M5	M10X1,25	62	2	8	70	78	10
32	14	22	3,5		6,2	M6	M10X1,25	72	2,5	8	80	88	10
40	16	24	5		8,2	M8	M12X1,25	76	3	9	85	94	14
50	20	32	7,5	G1/8	10,5	M10	M16X1,5	82	5	10	92	102	11
63	20	32	7,5	G1/8	10,5	M10	M16X1,5	82	5	10	92	102	11
80	20	32	7,5	G1/8	10,5	M10	M16X1,5	106	5	12	118	130	20

Angle bracket in zinc-plated steel

Ø 18 mm

Ø 25 mm

Ø 32 ÷ 80 mm

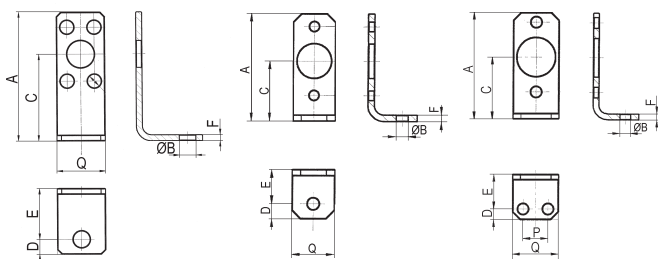

Cyl. Ø	A	ØB	C	D	E	F	P	Q	Part number
18	43	5,5	29	5	17	2	-	16	OVF-13018
25	50	5,5	28	7	16	3	-	20	OVF-13025
32	55	5,5	32	5,5	18	3	13	24	OVF-13032
40	65	5,5	40	7	20	4	16	30	OVF-13040
50	85	6,6	50	8	24	4	22	38	OVF-13050
63	105	9	63	10	27	4	30	50	OVF-13063
80	130	9	80	10	29	6	40	60	OVF-13080

Flange in aluminium alloy

Ø 18 mm

Ø 25 mm

Ø 32 ÷ 80 mm

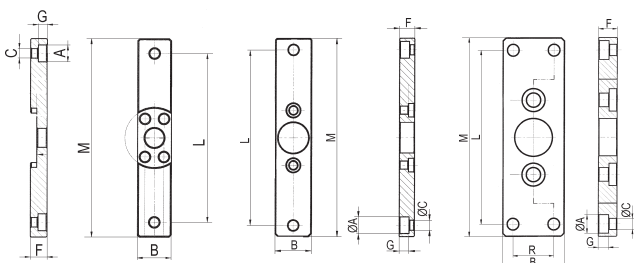

Cyl. Ø	ØA	B	ØC	F	G	L	M	R	Part number
18	8	16	4,5	8	4,3	80	94	-	OVF-12018
25	10	20	5,5	10	5,7	100	115	-	OVF-12025
32	11	24	6,6	10	6,3	115	130	-	OVF-12032
40	11	30	6,6	10	6,3	132	146	-	OVF-12040
50	15	38	9	12	8,3	140	160	21	OVF-12050
63	15	50	9	15	8,3	140	160	33	OVF-12063
80	15	60	9	20	8,3	178	200	40	OVF-12080

Male hinge in aluminium alloy

Ø 18 mm

Ø 25 ÷ 80 mm

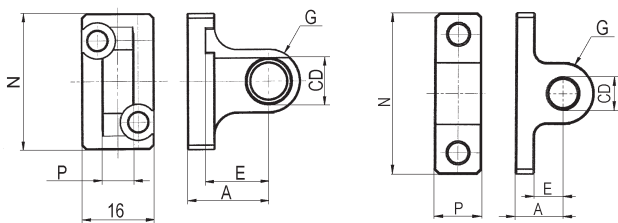

Cyl. Ø	A	CD ØH7	E	G	N	P H12	Part number
18	18	8	14	7	30	7	OVF-11018
25	14	8	8	7,5	42	9	OVF-11025
32	15	10	9	10	47	10,5	OVF-11032
40	18	12	12	13	52	10,5	OVF-11040
50	20	12	12	13	68	20	OVF-11050
63	24	16	16	17	80	25	OVF-11063
80	24	16	9	17	95	25	OVF-11080

Rod nut

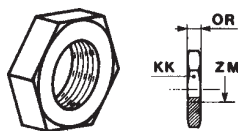

Fixing screws

Cylindrical screws UNI5931 (100 pcs.) for OVF-13.. Angle bracket

- Ø 18 AZ4-VN0408 Ø 40 AZ4-VN0514 Ø 80 AZ4-VN1020
- Ø 25 AZ4-VN0410 Ø 50 AZ4-VN0816
- Ø 32 AZ4-VN0510 Ø 63 AZ4-VN1018

Cylindrical screws DIN7984 (100 pcs.) for OVF-12.. Flange

- Ø 18 AZ4-VPA0408 Ø 40 AZ4-VPA0518 Ø 80 AZ4-VPA1025
- Ø 25 AZ4-VPA0414 Ø 50 AZ4-VPA0818
- Ø 32 AZ4-VPA0512 Ø 63 AZ4-VPA1018

Cylindrical screws UNI5931 (100 pcs.) for OVF-11.. Male hinge

- Ø 18 AZ4-VN0410 Ø 40 AZ4-VN0516 Ø 80 AZ4-VN1025
- Ø 25 AZ4-VN0412 Ø 50 AZ4-VN0820
- Ø 32 AZ4-VN0512 Ø 63 AZ4-VN1016

Cyl. Ø	ZM	KK	OR	Part number
18	M8	13	5	MF-16020
25	M10X1,25	17	6	KF-16032
32	M10X1,25	17	6	KF-16032
40	M12X1,25	19	7	KF-16040
50	M16X1,5	24	8	KF-16050
63	M16X1,5	24	8	KF-16050
80	M16X1,5	24	8	KF-16050