

A product which combines the familiar and traditional aspect of the UNIVER locking unit and a new and revolutionary “elastic heart” capable to improve its performances under every point of view. Maximum locking force, excellent response time, high kinetic energy which can be dissipated, excellent locking repeatability, high resistance to shock and vibrations.

TECHNICAL CHARACTERISTICS

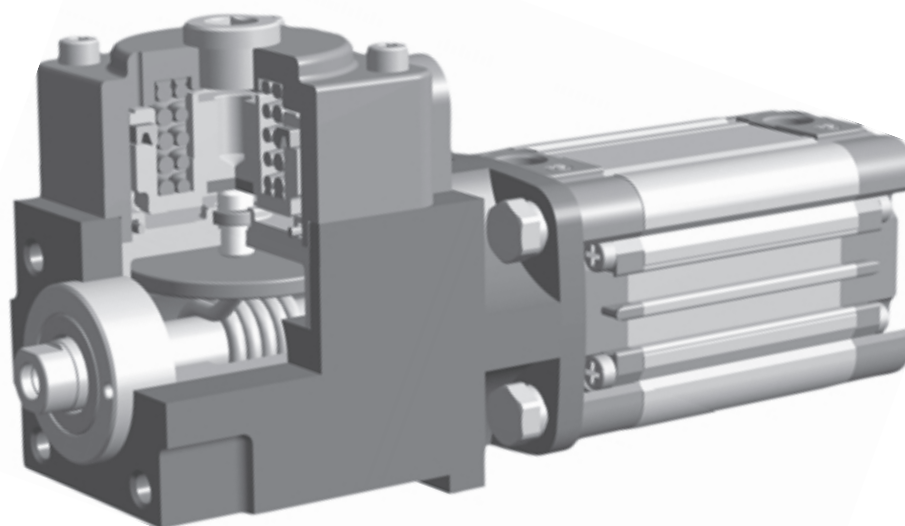

Codification key

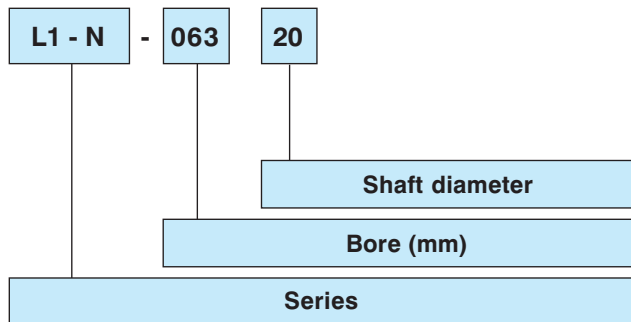

Fluid: filtered air, with or without lubrication
 Working pressure: 4,5 ÷ 10 bar
 Ambient temperature: -20° ÷ 80 °C

TECHNICAL CHARACTERISTICS

- * prearranged only for chromium-plated steel rods
- * the new series is completely interchangeable with the old one
- * the new locking units tolerate without problems load variations as well as the application of sudden loads.
- * the new series of locking units functions without problems also if rods or shafts are dirty with oil or grease.
- * Safety standards are perfectly complied with: the air pressure can only be used for releasing the device (4 bar).
- * **alternatively it is possible to use the integrated cylinder locking unit as shown on page 59-II.**

TYPE

1 Mechanical lock

BORE SIZES

Ø 16 ÷ 125

SHAFT DIAMETER

Ø 6 ÷ 32

Cylinder bore (mm)	16	20	25	32	40	50	63	80	100	125
Rod diameter (mm)	6	8	10	12	16	20	20	25	25	32
Pneumatic connection	G 1/8									
Mass (kg)	0,43	0,43	0,43	0,78	1	1,50	2,30	4	6,70	10,70



A spring in special steel, developed together with FEA (Finite Element Analysis) and with the assistance of the most advanced CAD technics, constitutes the heart of this new locking unit which, in addition to the excellent locking capacity and repeatability, enable a soft braking of the moved masses.

Main performances and characteristics:

Size or bore of the equivalent cylinder	16 (shaft 6)	20 (shaft 8)	25 (shaft 10)	32 (shaft 12)	40 (shaft 16)	50 (shaft 20)	63 (shaft 20)	80 (shaft 25)	100 (shaft 25)	125 (shaft 32)
Static locking force [N]	200	314	490	800	1260	2000	3100	5000	7850	12300
Pressure applied to the equivalent cylinder [bar]	10	10	10	10	10	10	10	10	10	10
Dynamic braking force at 1 m/s	40% of the static locking force									
Response time at 6 bar [ms]	12	12	15	20	20	25	25	30	30	40
Repeatability of locking point	< 1 mm a 1 m/s (see diagram below)									
Resistance to vibration	10 g (10-55 Hz) 30 min. on each axis									
Shock resistance [J]	2	3	4	5	8	11	15	21	29	40
Minimum release pressure [bar]*	4									

* For release pressure values under 4 bar, the reaction of the locking unit cannot be foreseen.

High-Tech

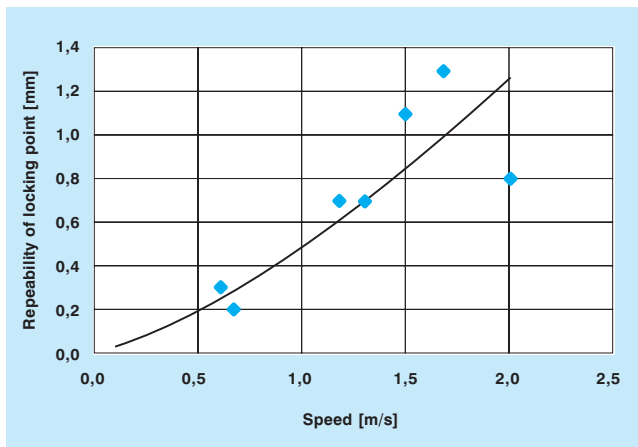

Braking distance

In some applications, it could be necessary to know the piston rod stroke between the reception of an emergency signal and its stop.

This value (S) depends on the following:

V = speed in emergency in m/s

t = locking system response time in seconds (approx. 0,03 sec.)

f = braking force under dynamic conditions in N

This displacement (S) is obtained by the following formula:

$$S = (V \cdot t) + \frac{m V^2}{2 f}$$

Example:

locking unit size 40 with dynamic load 10 kg at a speed of 0,7 m/s:

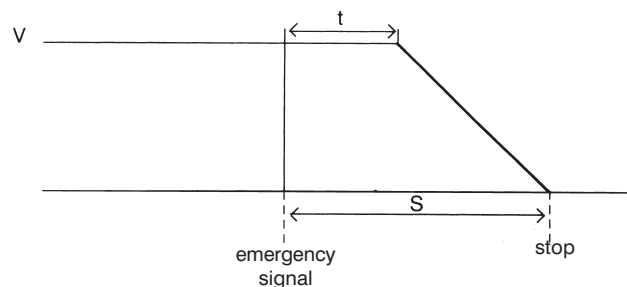
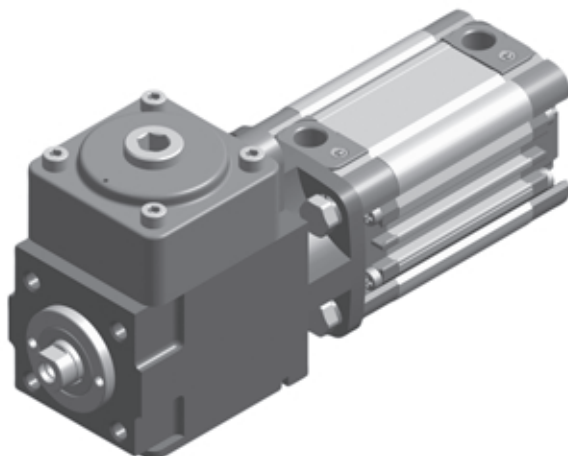

Locking units for Ø 16 - 20 - 25 mm ISO microcylinders

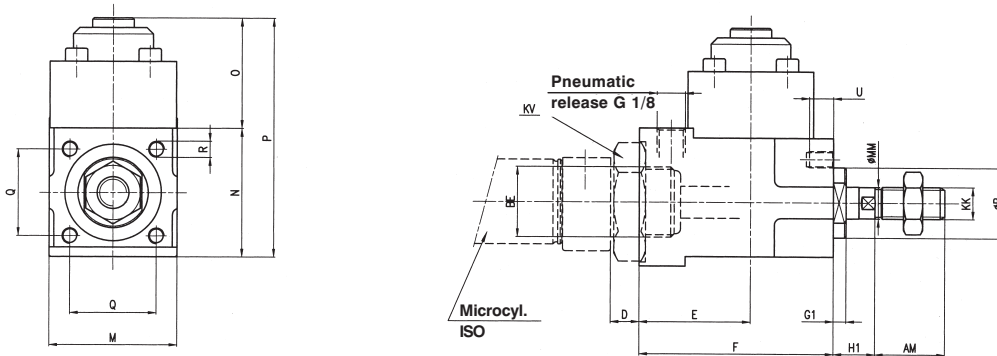

Additional length to the standard rod

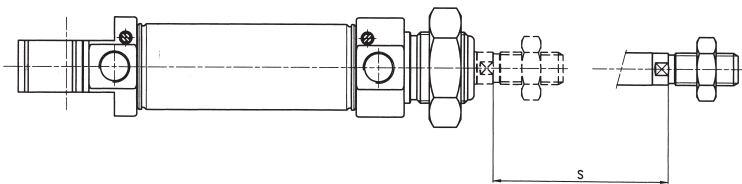

Cyl. Ø	AM	B	BE	D	E	F	G1	H1	KK	KV	M	MM	N	O	P	Q	R	S	U
16	16	16	M16 x 1,5	10	35	61	1,5	7	M6 x 1	es. 24	40	6	40	34,5	74,5	27	M5	55	7,5
20	20	22	M22 x 1,5	10	35	61	4	9	M8 x 1,25	es. 32	40	8	40	34,5	74,5	27	M5	55	7,5
25	22	22	M22 x 1,5	10	35	61	4	13	M10 x 1,25	es. 32	40	10	40	34,5	74,5	27	M5	55	7,5

Locking unit for compact cylinders STRONG Ø 32 - 63 mm

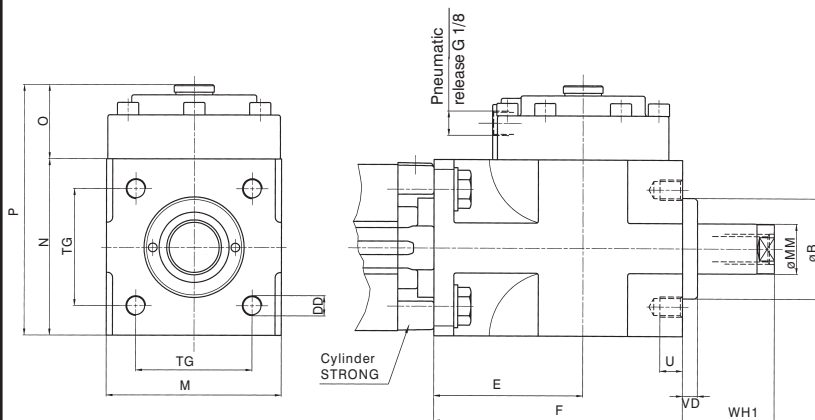

Fixing screws

Grain UNI 5923, washer and nut UNI 5589

Cyl. Ø	Small parts	Q.ty	Dimens.	Part number
32	Grain	4	M 6 x 30	AZ4-VS0630
	washer	4	6,4 x 16	AZ4-SR06,41,6
	nut	4	M 6 x 1	AZ4-SO0064
40	Grain	4	M 6 x 30	AZ4-VS0630
	washer	4	6,4 x 1,6	AZ4-SR06,41,6
	nut	4	M 6 x 1	AZ4-SO0064
50	Grain	4	M 8 x 40	AZ4-VS0840
	washer	4	8,4 x 1,6	AZ4-SR841,6
	nut	4	M 8 x 1,25	AZ4-SH08125
63	Grain	4	M 8 x 40	AZ4-VS0840
	washer	4	8,4 x 1,6	AZ4-SR8,41,6
	nut	4	M 8 x 1,25	AZ4-SH08125

Ø	B	DD	E	F	M	MM	N	O	P	TG	U	VD	WH1
32	30	M6	54,5	84	50	12	50	29,5	79,5	32,5	10	6	26
40	35	M6	58	90	58	16	58	29,5	87,5	38	9	6	30
50	40	M8	60	100	70	20	70	29	99	46,5	10	6	37
63	45	M8	65	110	85	20	85	37	122	56,5	13	6	37

Additional length to standard rod with ISO protrusion

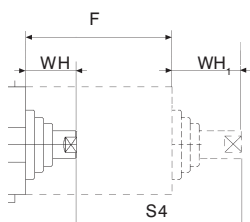

Cyl. Ø	WH	F	WH ₁	S4
32	14	84	26	96
40	14	90	30	106
50	18	100	37	119
63	18	110	37	129

Locking units for ISO cylinders $\varnothing 32 \div 125$

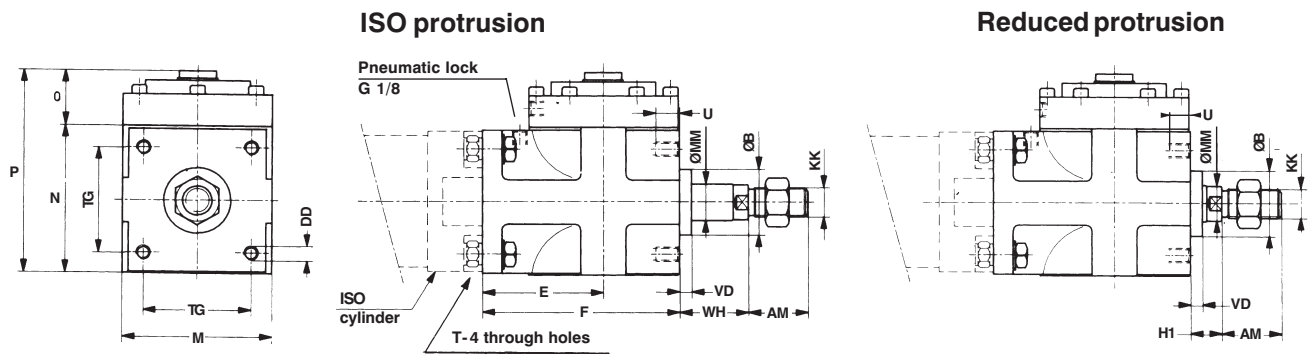

Additional length to the standard rod

S₁ for ISO dimensions

S₂ for reduced dimensions

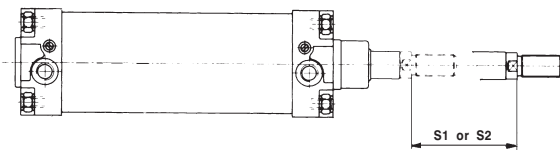

Cyl. \varnothing	AM	B	DD	E	F	H1	KK	M	MM	N	O	P	S1	S2	TG	U	VD	WH
32	22	30	M6	54,5	84	16	M10 x 1,25	50	12	50	29,5	79,5	85	75	32,5	10	6	26
40	24	35	M6	58	90	15	M12 x 1,25	58	16	58	29,5	87,5	90	75	38	9	6	30
50	32	40	M8	60	100	17	M16 x 1,5	70	20	70	29	99	100	80	46,5	10	6	37
63	32	45	M8	65	110	17	M16 x 1,5	85	20	85	37	122	110	90	56,5	13	6	37
80	40	45	M10	75	125	21	M20 x 1,5	100	25	100	40,5	140,5	125	100	72	16	8	46
100	40	55	M10	90	152	26	M20 x 1,5	116	25	120	59	179	150	125	89	18	8	51
125	54	60	M12	112,5	185	35	M27 x 2	145	32	145	62	207	185	155	110	22	9,5	65

Screw with hexagonal head UNI 5739 and washer UNI 6592 for assembling locking unit to ISO cylinder

Cyl. \varnothing		Quantity	Dimensions	Part number
32	screws	4	M6 x 16	AZ4-VE0616
	washer	4	6,4 x 1,6	AZ4-SR06,41,6
40	screws	4	M6 x 20	AZ4-VE0620
	washer	4	6,4 x 1,6	AZ4-SR06,41,6
50	screws	4	M8 x 20	AZ4-VE0820
	washer	4	8,4 x 1,6	AZ4-SR08,41,6
63	screws	4	M8 x 25	AZ4-VE0825
	washer	4	8,4 x 1,6	AZ4-SR08,41,6
80	screws	4	M10 x 30	AZ4-VE1030
	washer	4	10,5 x 2	AZ4-SR10,52,0
100	screws	4	M10 x 30	AZ4-VE1030
	washer	4	10,5 x 2	AZ4-SR10,52,0
125	screws	4	M12 x 35	AZ4-VE1235
	washer	4	13 x 2,5	AZ4-SR13,02,5

...other examples of locking unit applications...

...for gates...

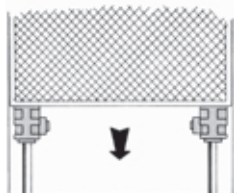

...for slides...

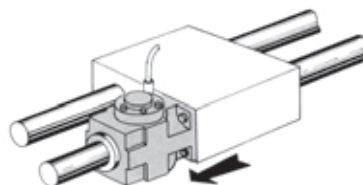

...for...

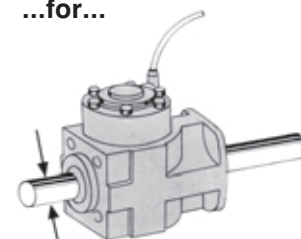

\varnothing	f8	f7
	6-8-10-12-14-16	20-25-32

Chromium-plated shaft