

size	0	1	2	
Part no.	HZE0D08GM	HZE1D10GM	HZE1D15GM	HZE2D15GM
Threaded port	G1/4	G3/8	G1/2	G1/2
Filtration rating (µm)	5	5	5	5
Flow NI/min (A)	600	2800	4300	
Max inlet pressure (bar-MPa-psi)	10-1-145	10-1-145	10-1-145	10-1-145
Pressure adjustment by relieving (bar)	0,5 ÷ 8,5	0,5 ÷ 8,5	0,5 ÷ 8,5	0,5 ÷ 8,5
Pressure gauge (standard supplied)	HZ9464G	HZ9464G	HZ9464G	HZ9464G
Pressure gauge port	G1/8 ^(B)	G1/8 ^(C)	G1/8 ^(C)	G1/8 ^(C)
Fluid	compressed air	compressed air	compressed air	compressed air
Temperature (°C)	0 ÷ 60	0 ÷ 60	0 ÷ 60	0 ÷ 60
Condensation drain capacity (cm3)	12	45	80	
Condensation drain	manual	manual	manual	manual
Weight (Kg)	0,33	1,05	1,55	
Mounting position	vertical	vertical	vertical	vertical
Recommended oil	ISO VG 32	ISO VG 32	ISO VG 32	ISO VG 32
Minimum working flow (l/min)	25	30	65	

(A) = inlet pressure 6 bar, outlet pressure 5 bar - Δp 1 bar

(B) = optional (replace HZ9464G gauge with G1/8 adaptor HZE7Z480 to be ordered separately)

(C) = standard (replace HZ9464G gauge with G1/8 adaptor HZE7Z480 placed on the back side)

HZE0D08GM

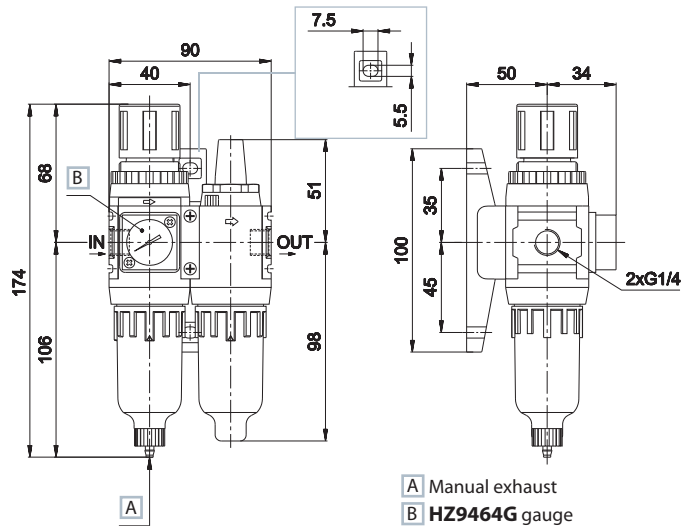
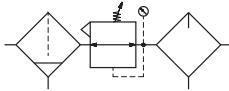

HZE1D10GM - HZE2D15GM

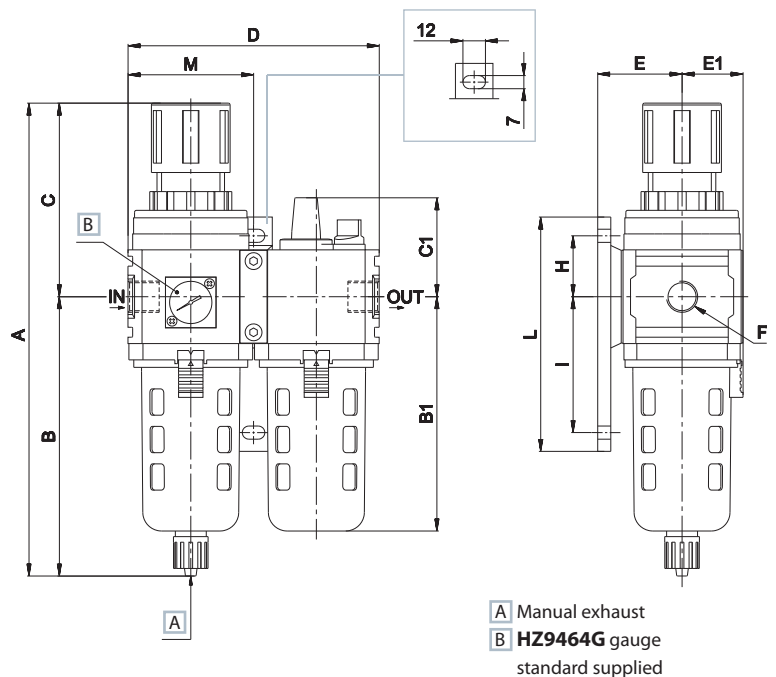
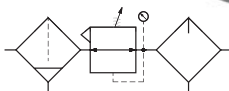

size	A	B	B1	C	C1	D	E	E1	F	H	I	L	M
1	259	156	130	103	52,5	126	45	31,5	G3/8-G1/2	45	60	125	63
2	280	170	148	110	53,5	160	55	40	G1/2	45	60	125	80