

RP-RM

Ø16 ÷ 100 mm UNITOP, ISO 21287 Compact Cylinders

- Non-rotating and extended piston rod version available
- Equipped with pneumatic adjustable cushioning for a sensible reduction of noise
- Magnetic version standard supplied

Available ATEX version upon request



TECHNICAL CHARACTERISTICS

Ambient temperature	-20 ÷ 80 °C
Fluid	filtered air, with or without lubrication
Working pressure	1,5 ÷ 10 bar
Bores	Ø 16 - 20 - 25 - 32 - 40 - 50 - 63 - 80 - 100 mm
Cushionings	adjustable in both sides (UNIVER Original standard supplied)

CONSTRUCTIVE CHARACTERISTICS

End-caps	die-cast zamak (Ø 16 ÷ 25 mm), aluminium (Ø 32 ÷ 100 mm)
Barrel	anodized aluminium
Piston	aluminium
Guide slide	acetalic resin
Piston rod	chromium-plated steel (standard), rolled stainless steel AISI 303
Piston seal	nitrile rubber (NBR)
Guide bush for piston rod	acetalic resin
Shock absorber seals	plasto-ferrite (NBR) on both sides
Magnet	plasto-ferrite (standard supplied)

CODIFICATION KEY

R	P	2	0	1	0	3	2	0	0	2	5		
1	2	3	4				5					6	7

1 Series		2 Type		3 Version							
RP = Ø 16÷63 mm UNITOP Compact Cylinders	RM = Ø 16÷100 mm - ISO 21287 Compact Cylinders	RP 1 = Stainless steel female piston rod 2 = Chromium-plated steel female piston rod RM 3 = Stainless steel male piston rod 4 = Chromium-plated steel male piston rod	Type 1 - 2 00 = D.A. Standard version 01 = D.A. Through piston rod 10 = D.A. Non-rotating guided piston rod 11 = D.A. Non-rotating guided through piston rod 20 = D.A. Long piston (Ø32÷63) 60 = S.A. Retracted piston rod 70 = S.A. Extended piston rod	Type 3 - 4 00 = D.A. Standard version 01 = D.A. Through piston rod 20 = D.A. Long piston (Ø32÷63) 60 = S.A. Retracted piston rod 70 = S.A. Extended piston rod D.A. = Double acting S.A. = Single acting							
4 Bore (mm)		5 Stroke (mm)		6 Option							
016 = Ø16 020 = Ø20 025 = Ø25 032 = Ø32 040 = Ø40 050 = Ø50 063 = Ø63 080 = Ø80 (only RM) 100 = Ø100 (only RM)	Single acting 0005-0010 (Ø16 ÷ 25 mm) 0005-0010-0015-0020-0025 (Ø32 ÷ 100 mm) Double acting 0005-0010-0015-0020-0025-0030-0040-0050-0060-0080 Max standard stroke Ø16 0040 mm Ø20-25 0050 mm Ø32-63 0080 mm	Max stroke with non-rotating guided piston rod (upon request) Ø16 0100 mm Ø20-25 0200 mm Ø32-40 0400 mm Ø50-63 0500 mm	C = With flange for RP series, versions: 200-201-260-270 and 100-101-120-160-170 H = Hollow piston rod only for through piston rod versions without flange								
				7 Atex option							
				X = Atex (upon request) See ATEX Catalogue for types and versions							

For high temperature applications please contact our Sales Office

Subject to change

Stroke tolerances

Ø	mm
16	+1,5 - 0
20	+1,5 - 0
25	+1,5 - 0
32	+2 - 0
40	+2 - 0
50	+2 - 0
63	+2,5 - 0
80	+4 - 0
100	+4 - 0

Single acting cylinder
Spring return theoretical forces (N)

Ø	Max force	Min force	Max stroke	Decrease for mm stroke
	N	N	mm	N/mm
16	14	11,8	10	0,22
20	23,5	20	10	0,35
25	23,5	20	10	0,35
32	40	24	25	0,64
40	50	35	25	0,6
50	90	49	25	1,64
63	90	49	25	1,64
80	120	60	25	2,4
100	160	92,5	25	2,7

Theoretical forces (N)
at working pressure (bar)

Ø	Surface area		Working pressure					Working pressure				
	mm ²		bar					bar				
	Thrust	Traction	Thrust					Traction				
			2	4	6	8	10	2	4	6	8	10
16	201	151	40	80	121	161	201	30	60	91	121	151
20	314	236	63	126	188	251	314	47	94	142	189	236
25	491	412	98	196	295	393	491	82	165	247	330	412
32	804	691	161	322	482	643	804	138	276	414	553	691
40	1256	1143	251	502	754	1005	1256	228	457	685	914	1143
50	1962	1762	393	785	1178	1570	1963	352	704	1057	1409	1762
63	3116	2916	623	1246	1869	2493	3116	583	1166	1749	2332	2916
80	5024	4710	1005	2010	3014	4019	5024	942	1884	2826	3768	4710
100	7850	7536	1570	3140	4710	6280	7850	1507	3014	4521	6029	7536

1

CYLINDERS

Mass - Standard cylinder and long piston version

Ø	Cylinder - stroke 0 Standard		Cylinder - stroke 0 Long piston		Increase for mm stroke	Moving element stroke 0 - Standard		Moving element stroke 0 - Long piston		Increase for mm stroke
	g		g		g	g		g		g
	RP200	RM400	RP220	RM420	RP200/220 - RM400/420	RP200	RM400	RP220	RM420	RP200/220 - RM400/420
16	103	115	-	-	1,05	15,5	27,5	-	-	0,39
20	135	157	-	-	1,45	24,5	46,5	-	-	0,62
25	203	225	-	-	1,65	34,5	56,5	-	-	0,62
32	205	240	291,5	326,5	2,65	60	95	115,5	146,5	0,9
40	305	340	426	461	3,3	75	110	148	183	0,9
50	450	505	676,5	731,5	4,7	125	180	274	329	1,6
63	735	790	1063,5	1198,5	5,65	200	255	427	482	1,6
80	-	1146	-	-	8,95	-	285	-	-	2,1
100	-	1966	-	-	11,05	-	298	-	-	2,3

Mass - Through piston rod cylinder

Ø	Cylinder - stroke 0		Increase for mm stroke	Moving element - stroke 0		Increase for mm stroke
	g		g	g		g
	RP201	RM401	RP201 - RM401	RP201	RM401	RP201 - RM401
16	105	129	1,45	17,5	41,5	0,78
20	138	182	2,07	24,8	68,8	1,24
25	206	250	2,27	34,8	78,8	1,24
32	230	290	3,55	85	125	1,8
40	325	390	4,2	100	140	1,8
50	490	570	6,3	165	225	3,2
63	775	855	7,25	245	300	3,2
80	-	1261	11,4	-	335	3,6
100	-	2128	13,5	-	355	3,9

Mass - Retracted and extended piston rod cylinder

Ø	Cylinder - stroke 0 Retracted piston rod		Cylinder - stroke 0 Extended piston rod		Increase for mm stroke Retracted/extended piston rod	Moving mass - stroke 0 Retracted/extended piston rod		Increase for mm stroke Retracted/extended piston rod
	g		g		g	g		g
	RP260	RM460	RP270	RM470	RP260/RM460 - RP270/RM470	RP260/RP270	RM460/RM470	RP260/RM460 - RP270/RM470
16	103	115	103	115	1,05	15,5	27,5	0,39
20	135	157	135	157	1,45	24,5	46,5	0,62
25	203	225	203	225	1,65	34,5	56,5	0,62
32	215	250	203	238	2,65	63	98	0,9
40	315	350	302	337	3,3	81	116	0,9
50	468	523	445	500	4,7	137	192	1,6
63	753	808	730	785	5,65	212	267	1,6
80	-	1182	-	1182	8,95	-	289	1,9
100	-	2002	-	2002	11,05	-	310	2,2

Cylinder mass with non-rotating device
and through piston rod with non-rotating device

Ø	Cylinder - stroke 0		Increase for mm stroke		Moving mass - stroke 0		Increase for mm stroke	
	g		g		g		g	
	RP210	RP211	RP210	RP211	RP210	RP211	RP210	RP211
16	122	124	1,25	1,64	34,5	36,7	0,59	0,98
20	165	168	1,75	2,37	54,5	57,5	0,93	1,65
25	240	243	1,95	2,57	71,5	74,5	0,93	1,55
32	245	270	3,09	3,99	100	125	1,34	2,24
40	372	392	4,1	5	142	167	1,7	2,6
50	545	585	5,5	7,1	220	260	2,4	4
63	875	915	6,89	8,49	340	385	2,84	4,44

Peak load

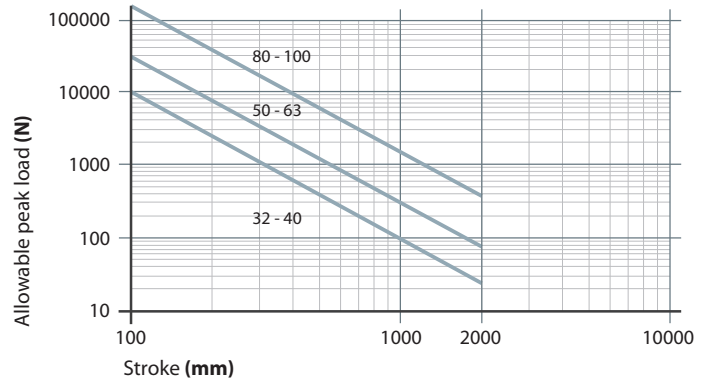
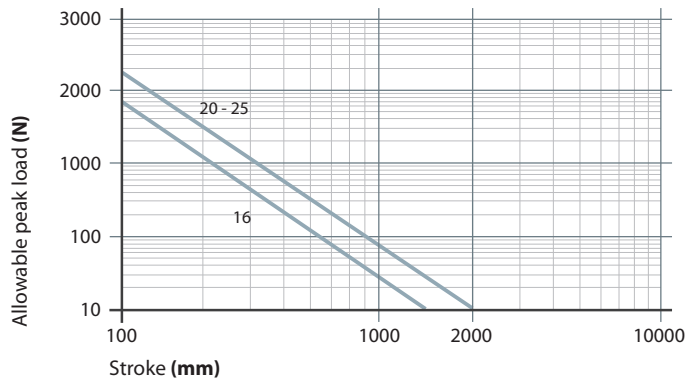

Graph of side load on piston rod

Standard piston Ø16 ÷ 25 mm

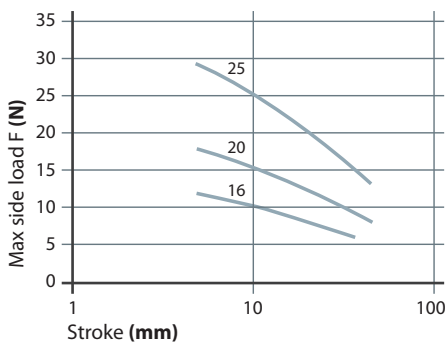

Standard piston Ø32 ÷ 100 mm

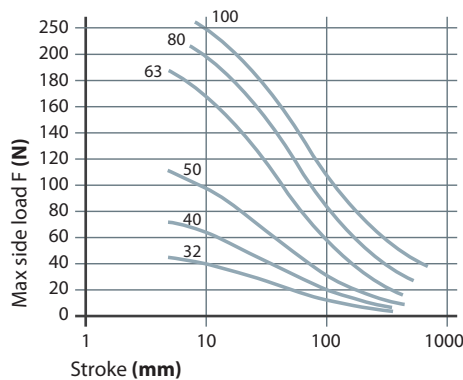

Long piston Ø32 ÷ 63 mm

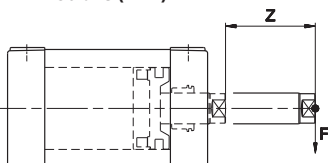
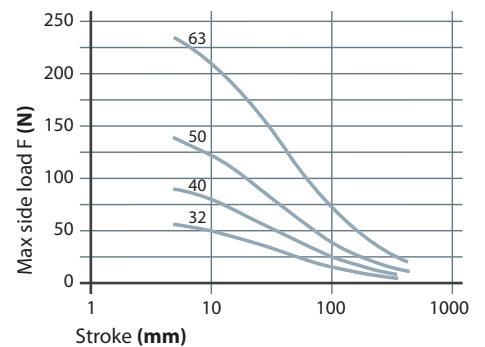

Z = Stroke
F = Force

■ RP Ø 16 ÷ 63 fixing elements and accessories

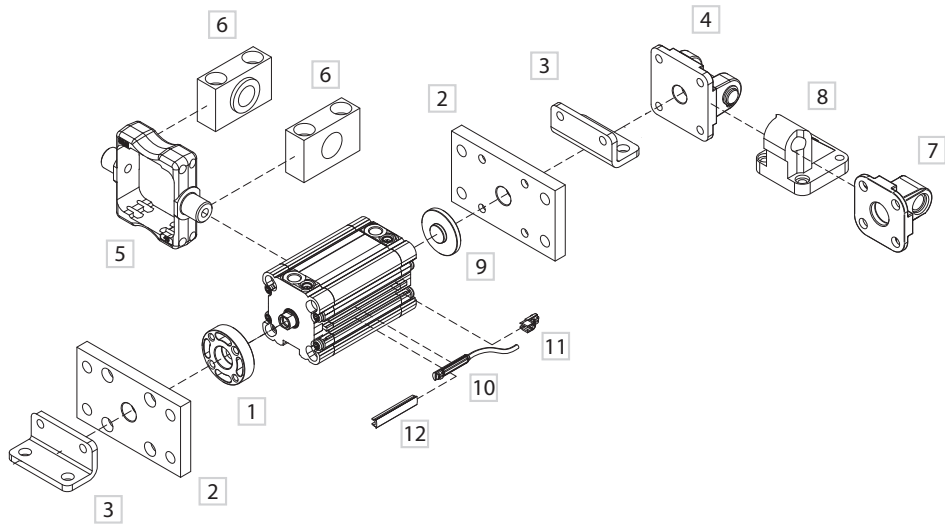

1
CYLINDERS

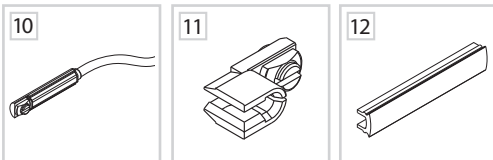

DESCRIPTION	PART NO.
1 Flange for female piston rod	RPF-28 ___
2 Front/rear flange	RPF-12 ___ / KF-12 ___ (Ø32)
3 Angle bracket	RPF-13 ___ / KF-13 ___ (Ø32)
4 Rear female hinge with pin	RPF-10 ___ A / KF-10 ___ A (Ø32)
5 Intermediate hinge	RPF-14 ___ / KDF-14 ___ (Ø32)
6 Hinge support	KF-41 ___
7 Rear male hinge	RPF-11 ___ / KF-11 ___ (Ø32)
8 Counter hinge 90°	KF-19 ___ Ø32 ÷ 63
9 Centering adaptor ring	RSF-09 ___ Ø32 ÷ 63
10 DF sensor (see accessories section)	DF-___
11 Cable clamping for DF sensor (see accessories section)	DF-001
12 DHF covering strip (see accessories section)	DHF-0020100

RM Ø 16 ÷ 100 fixing elements and accessories

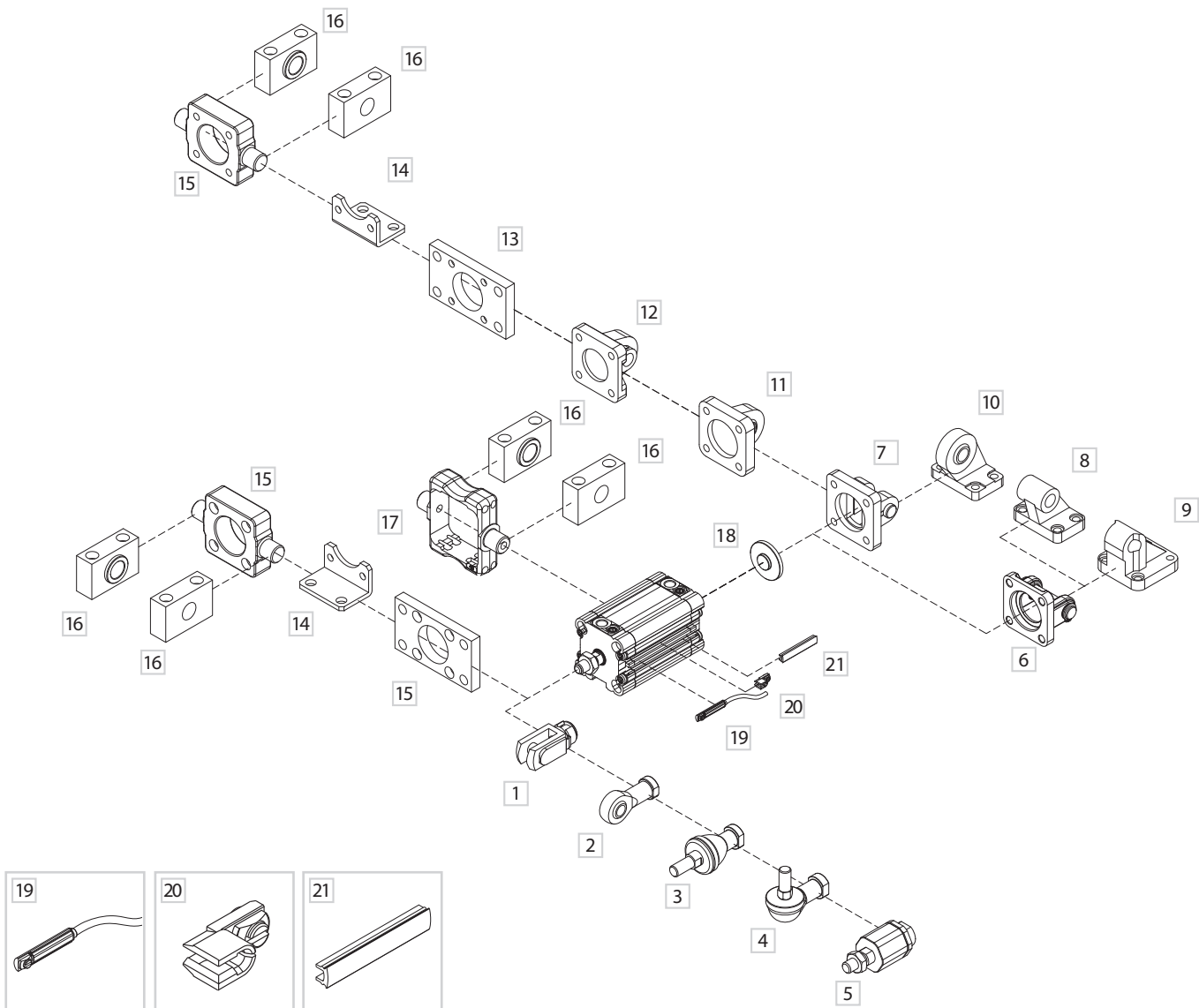

DESCRIPTION	PART NO.
1 Female fork with clips	KF-15___ / MF-15___ (Ø16-20-25)
2 Articulated self-lubricating fork	KF-17___ / MF-17___ (Ø16-20-25)
3 Fork with axially mounted articulated pin	KF-22___ / MF-22___ (Ø16-20-25)
4 Fork with angle mounted articulated pin	KF-23___ / MF-23___ (Ø16-20-25)
5 Floating joint	KF-24___ / MF-24___ (Ø16-20-25)
6 Female rear hinge with pin	KF-10___A
7 Narrow female hinge with pin	KF-10___AS
8 Counter hinge 90° (CETOP)	KF-19___CTA
9 Counter hinge 90°	KF-19___
10 Articulated counter hinge	KF-19___SC
11 Articulated rear male hinge	KF-11___S
12 Rear male hinge	KF-11___ RPF (Ø16-20-25)
13 Front/rear flange	KF-12___ RPF (Ø16-20-25)
14 Angle bracket	KF-13___ RPF (Ø16-20-25)
15 Front/rear hinge with floating pin	KF-14___AP
16 Hinge support	KF-41___
17 ISO intermediate hinge	KDF-14___ (Ø32)/ RPF-14___ (Ø40-50-63)
18 Centering adaptor ring	RSF-09___ (Ø32÷100)
19 DF Sensor (see accessories section)	DF-___
20 Cable clamping for DF sensor (see accessories section)	DF-001
21 DHF covering strip (see accessories section)	DHF-0020100

Double acting RP - RM Ø 16 ÷ 25

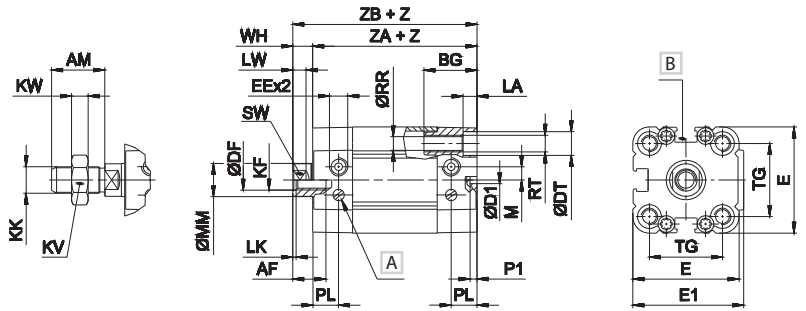
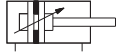

Z = Stroke

Double acting RP - RM Ø 32 ÷ 63

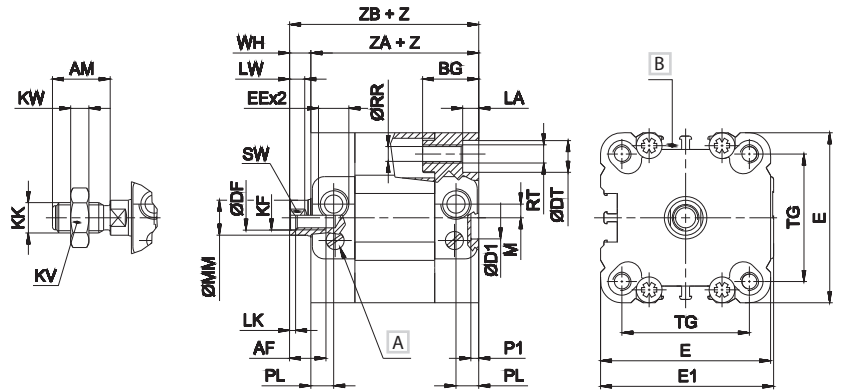
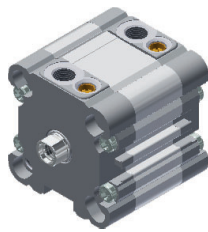

Z = Stroke

Double acting RM Ø 80 - 100

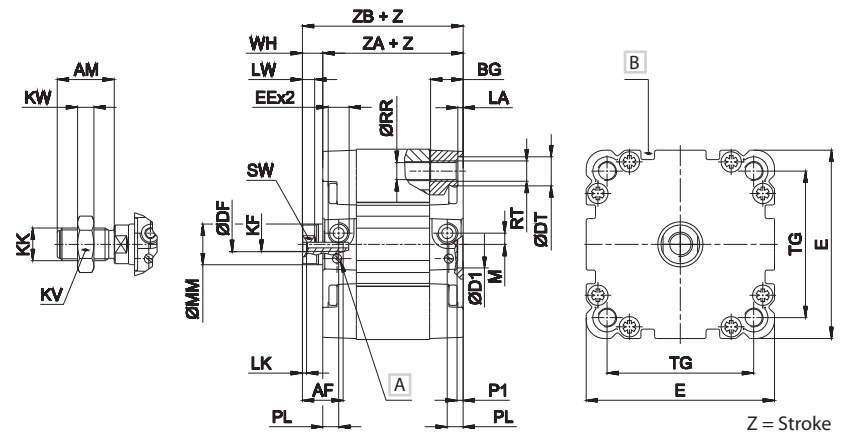
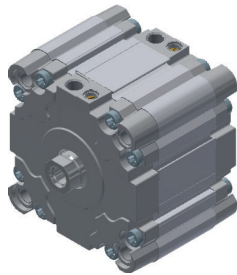

Z = Stroke

Ø	AM	AF	BG	DF	DT	D1	E	EE	E1	KF	KK	KV	KW	LA
16	12	8	16	4,1	5,8	2	28	M5	30	M4	M6x1	10	4	3,2
20	16	10	16	6,1	7,3	2	32	M5	34	M6	M8x1,25	13	5	4,2
25	16	10	16	6,1	8	2	37	M5	39	M6	M8x1,25	13	5	4,5
32	19	12	18	8,2	9	14	46	G1/8	47	M8	M10x1,25	17	6	5,3
40	19	12	18	8,2	9	14	56	G1/8	57	M8	M10x1,25	17	6	5,3
50	22	16	24	10,2	11	18	66	G1/8	67	M10	M12x1,25	19	7	6,5
63	22	16	24	10,2	11	18	79	G1/8	80	M10	M12x1,25	19	7	6,5
80	28	20	16,5	12,2	14	23	93,5	G1/8	-	M12	M16x1,5	24	9	2,6
100	28	20	21,5	12,2	14	28	112	G1/8	-	M12	M16x1,5	24	9	2,6

Ø	LK	LW	M	MM	PL	P1	RR	RT	SW	TG	WH	ZA	ZB
16	1	4,5	3,5	8	8	2	3,2	M4	7	18	5	37	42
20	1	4,5	4	10	8	2	4,2	M5	8	22	6	37	43
25	1	4,5	4	10	8	2	4,2	M5	8	26	6	39	45
32	2	5	4,5	12	7,5	2,5	5,2	M6	10	32,5	7	44	51
40	2	5	4,5	12	7,5	2,5	5,2	M6	10	42*	7	45	52
50	2	6	6,5	16	7,5	2,5	6,5	M8	13	50*	8	45	53
63	2	6	6,5	16	7,5	2,5	6,5	M8	13	62*	8	50	58
80	2	6	5,5	20	8	3	8,4	M10	17	72	10	54	64
100	2	6	8	20	10,5	3	8,4	M10	17	89	10	67	77

A Pneumatic cushioning adjusting screw

B Groove for sensor

Ø80 - Ø100 only for RM series

* = Dimensional variations for end-caps with ISO inter-axes (RM series): Ø40 38 mm - Ø50 46,5 mm - Ø63 56,5 mm

For cylinder version with long piston, dimensions ZA - ZB will be increased by 20 mm (Ø32 - Ø40), and 25 mm (Ø50 - Ø63)

Double acting through piston rod RP- RM Ø 16 ÷ 25

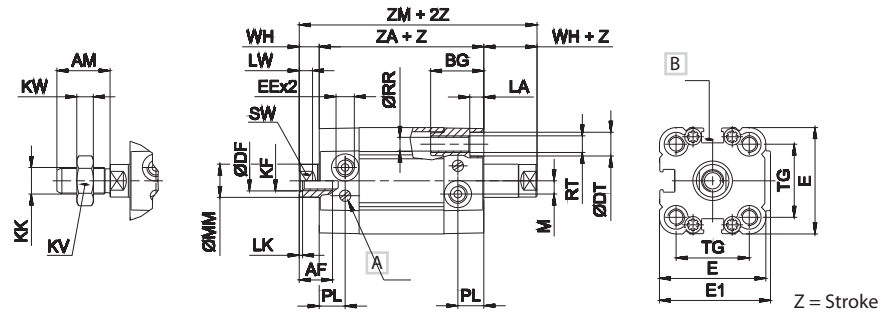
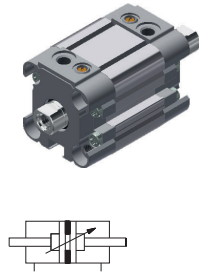

Double acting through piston rod RP- RM Ø 32 ÷ 63

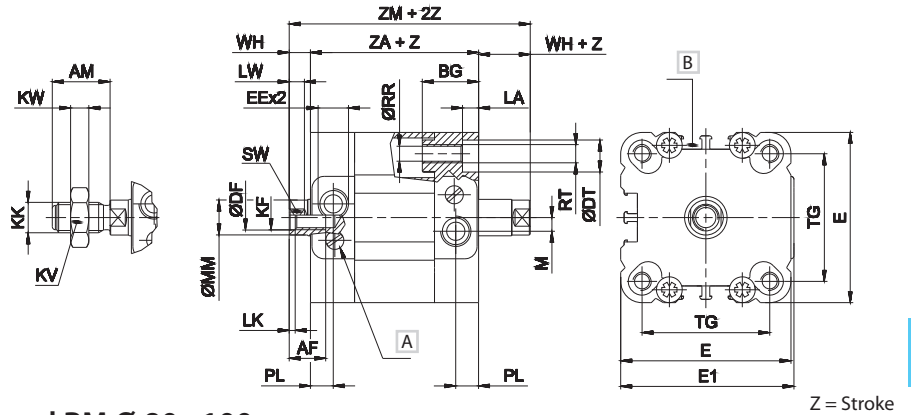
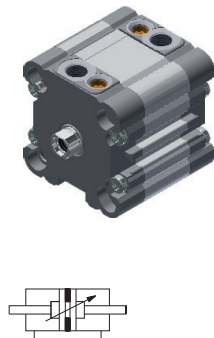

Double acting through piston rod RM Ø 80 - 100

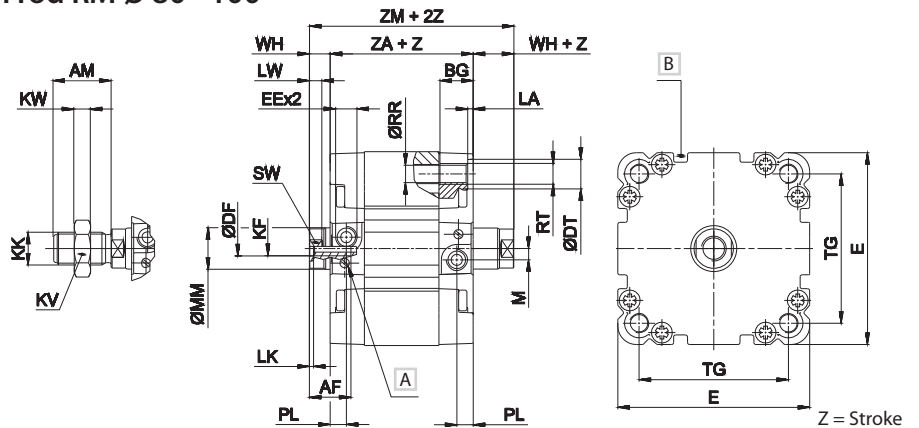
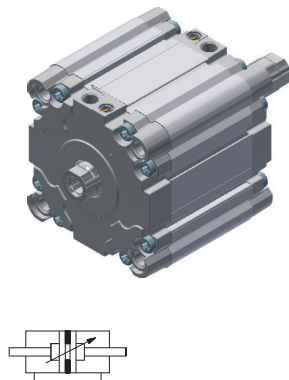

Ø	AM	AF	BG	DF	DT	E	EE	E1	KF	KK	KV	KW	LA
16	12	8	16	4,1	5,8	28	M5	30	M4	M6x1	10	4	3,2
20	16	10	16	6,1	7,3	32	M5	34	M6	M8x1,25	13	5	4,2
25	16	10	16	6,1	8	37	M5	39	M6	M8x1,25	13	5	4,5
32	19	12	18	8,2	9	46	G1/8	47	M8	M10x1,25	17	6	5,3
40	19	12	18	8,2	9	56	G1/8	57	M8	M10x1,25	17	6	5,3
50	22	16	24	10,2	11	66	G1/8	67	M10	M12x1,25	19	7	6,5
63	22	16	24	10,2	11	79	G1/8	80	M10	M12x1,25	19	7	6,5
80	28	20	16,5	12,2	14	93,5	G1/8	-	M12	M16x1,5	24	9	2,6
100	28	20	21,5	12,2	14	112	G1/8	-	M12	M16x1,5	24	9	2,6

Ø	LK	LW	M	MM	PL	RR	RT	SW	TG	WH	ZA	ZM
16	1	4,5	3,5	8	8	3,2	M4	7	18	5	37	47
20	1	4,5	4	10	8	4,2	M5	8	22	6	37	49
25	1	4,5	4	10	8	4,2	M5	8	26	6	39	51
32	2	5	4,5	12	7,5	5,2	M6	10	32,5	7	44	58
40	2	5	4,5	12	7,5	5,2	M6	10	42*	7	45	59
50	2	6	6,5	16	7,5	6,5	M8	13	50*	8	45	61
63	2	6	6,5	16	7,5	6,5	M8	13	62*	8	50	66
80	2	6	5,5	20	8	8,4	M10	17	72	10	54	74
100	2	6	8	20	10,5	8,4	M10	17	89	10	67	87

A Pneumatic cushioning adjusting screw
 B Groove for sensor

Ø80 - Ø100 only for RM series

* = Dimensional variations for end-caps with ISO inter-axes (RM series): Ø40 38 mm - Ø50 46,5 mm - Ø63 56,5 mm

Double acting female/male hollow through piston rod Ø 16 ÷ 100

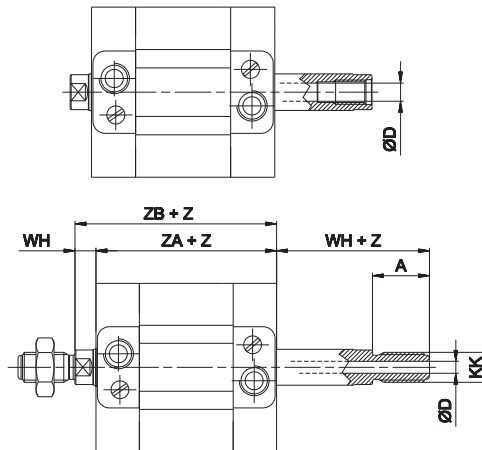

Z = Stroke

Ø	D
16	2
20	2,5
25	2,5
32	3,5
40	3,5
50	4,5
63	4,5
80	6
100	8

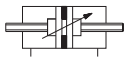

Ø16 ÷ 25 Max stroke **50 mm** Ø32 ÷ 63 Max stroke **75 mm** Ø80 - 100 Max stroke **100 mm**
 For all other dimensions please refer to the through piston rod version at the previous page

Double acting long piston Ø 32 ÷ 63

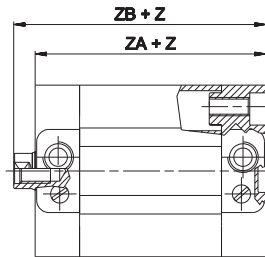

Z = Stroke

Ø	ZA	ZB
32	64	71
40	65	72
50	70	78
63	75	83

Single acting retracted piston rod RP - RM Ø 16 ÷ 25

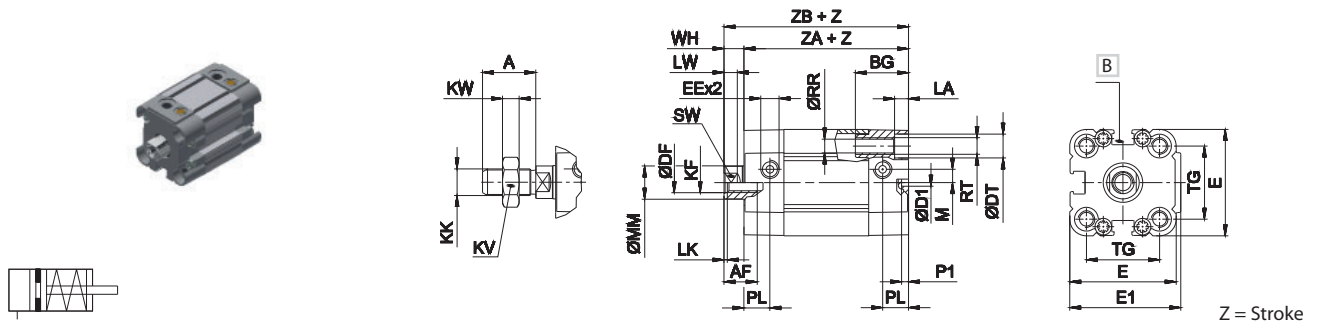

Single acting retracted piston rod RP - RM Ø 32 ÷ 63

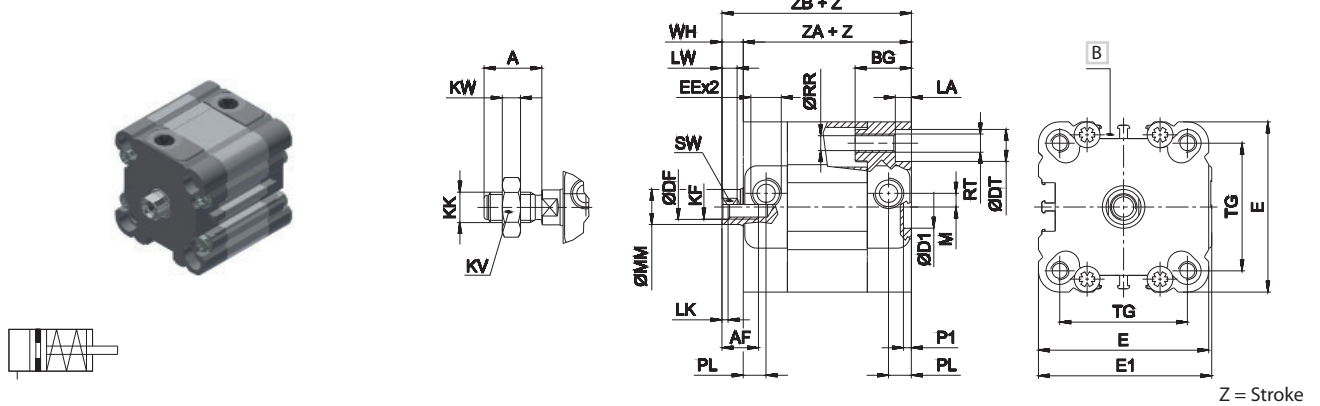

Single acting retracted piston rod RM Ø 80 - 100

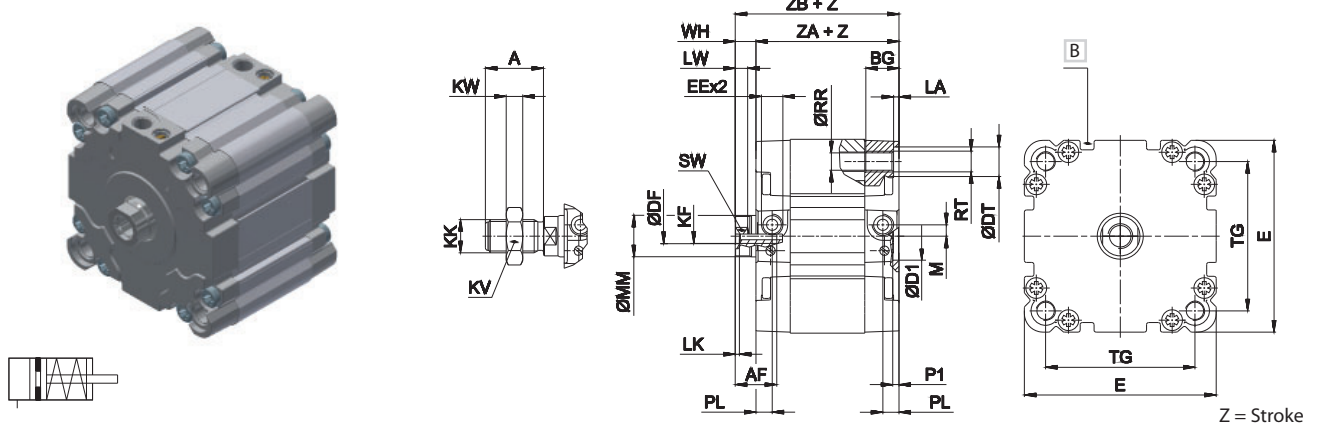

Ø	A	AF	BG	DF	DT	D1	E	EE	E1	KF	KK	KV	KW	LA
						H11								
16	12	8	16	4,1	5,8	2	28	M5	30	M4	M6x1	10	4	3,2
20	16	10	16	6,1	7,3	2	32	M5	34	M6	M8x1,25	13	5	4,2
25	16	10	16	6,1	8	2	37	M5	39	M6	M8x1,25	13	5	4,5
32	19	12	18	8,2	9	14	46	G1/8	47	M8	M10x1,25	17	6	5,3
40	19	12	18	8,2	9	14	56	G1/8	57	M8	M10x1,25	17	6	5,3
50	22	16	24	10,2	11	18	66	G1/8	67	M10	M12x1,25	19	7	6,5
63	22	16	24	10,2	11	18	79	G1/8	80	M10	M12x1,25	19	7	6,5
80	28	20	16,5	12,2	14	23	93,5	G1/8	-	M12	M16x1,5	24	9	2,6
100	28	20	21,5	12,2	14	28	112	G1/8	-	M12	M16x1,5	24	9	2,6

Ø	LK	LW	M	MM	PL	P1	RR	RT	SW	TG	WH	ZA	ZB
16	1	4,5	3,5	8	8	2	3,2	M4	7	18	5	37	42
20	1	4,5	4	10	8	2	4,2	M5	8	22	6	37	43
25	1	4,5	4	10	8	2	4,2	M5	8	26	6	39	45
32	2	5	4,5	12	7,5	2,5	5,2	M6	10	32,5	7	44	51
40	2	5	4,5	12	7,5	2,5	5,2	M6	10	42*	7	45	52
50	2	6	6,5	16	7,5	2,5	6,5	M8	13	50*	8	45	53
63	2	6	6,5	16	7,5	2,5	6,5	M8	13	62*	8	50	58
80	2	6	5,5	20	8	3	8,4	M10	17	72	10	54	64
100	2	6	8	20	10,5	3	8,4	M10	17	89	10	67	77

[B] Groove for sensor

Ø80 - Ø100 only for RM series

* = Dimensional variations for end-caps with ISO inter-axes (RM series): Ø40 38 mm - Ø50 46,5 mm - Ø63 56,5 mm

Single acting extended piston rod RP - RM Ø 16 ÷ 25

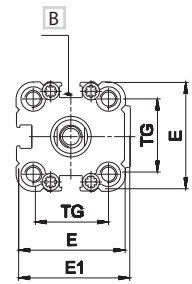
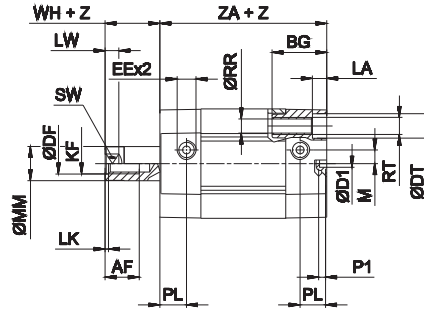
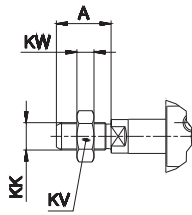

Z = Stroke

Single acting extended piston rod RP - RM Ø 32 ÷ 63

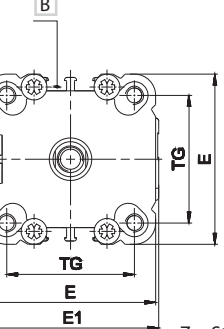
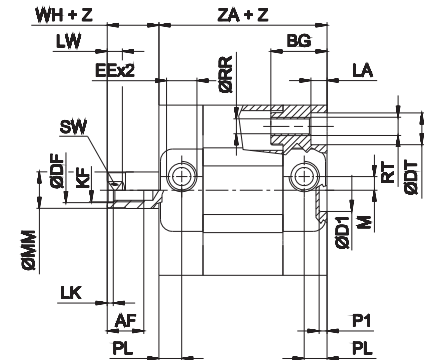
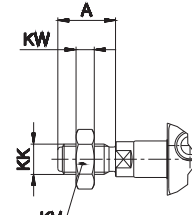

Z = Stroke

Single acting extended piston rod RM Ø 80 - 100

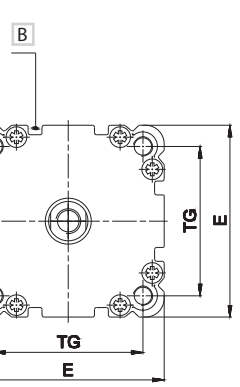
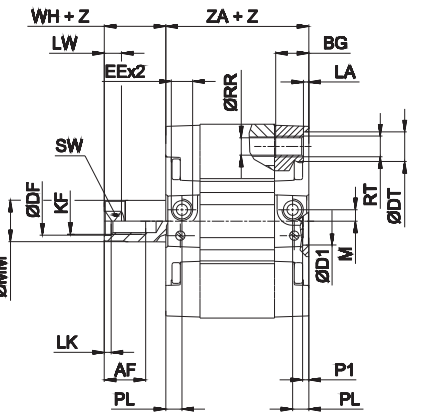
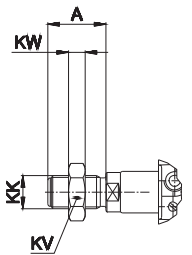
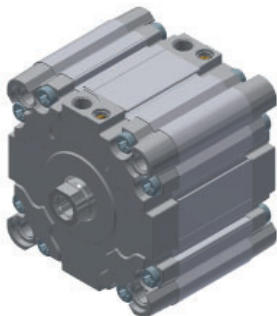

Z = Stroke

Ø	A	AF	BG	DF	DT	D1	E	EE	E1	KF	KK	KV	KW
16	12	8	16	4,1	5,8	H11	28	M5	30	M4	M6x1	10	4
20	16	10	16	6,1	7,3	2	32	M5	34	M6	M8x1,25	13	5
25	16	10	16	6,1	8	2	37	M5	39	M6	M8x1,25	13	5
32	19	12	18	8,2	9	14	46	G1/8	47	M8	M10x1,25	17	6
40	19	12	18	8,2	9	14	56	G1/8	57	M8	M10x1,25	17	6
50	22	16	24	10,2	11	18	66	G1/8	67	M10	M12x1,25	19	7
63	22	16	24	10,2	11	18	79	G1/8	80	M10	M12x1,25	19	7
80	28	20	16,5	12,2	14	23	93,5	G1/8	-	M12	M16x1,5	24	9
100	28	20	21,5	12,2	14	28	112	G1/8	-	M12	M16x1,5	24	9

Ø	LA	LK	LW	M	MM	PL	P1	RR	RT	SW	TG	WH	ZA
16	3,2	1	4,5	3,5	8	8	2	3,2	M4	7	18	5	37
20	4,2	1	4,5	4	10	8	2	4,2	M5	8	22	6	37
25	4,5	1	4,5	4	10	8	2	4,2	M5	8	26	6	39
32	5,3	2	5	4,5	12	7,5	2,5	5,2	M6	10	32,5	7	44
40	5,3	2	5	4,5	12	7,5	2,5	5,2	M6	10	42*	7	45
50	6,5	2	6	6,5	16	7,5	2,5	6,5	M8	13	50*	8	45
63	6,5	2	6	6,5	16	7,5	2,5	6,5	M8	13	62*	8	50
80	2,6	2	6	5,5	20	8	3	8,4	M10	17	72	10	54
100	2,6	2	6	8	20	10,5	3	8,4	M10	17	89	10	67

B Groove for sensor

Ø80 - Ø100 only for RM series

* = Dimensional variations for end-caps with ISO inter-axes (RM series): Ø40 38 mm - Ø50 46,5 mm - Ø63 56,5 mm

1
CYLINDERS

Double acting non-rotating guided piston rod RP Ø 16 ÷ 25

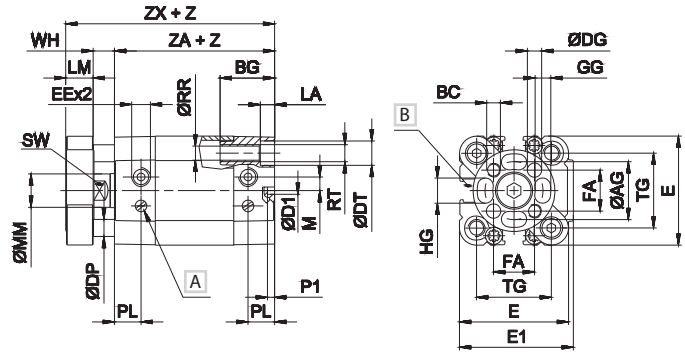
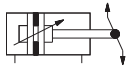

Z = Stroke

Double acting non-rotating guided piston rod RP - RM Ø 32 ÷ 63

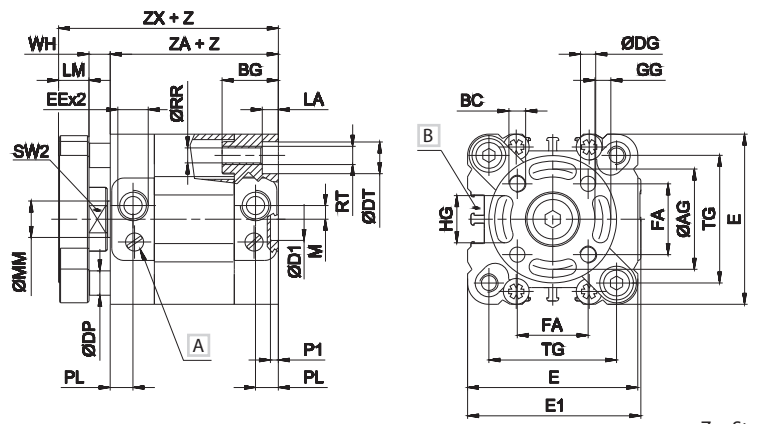
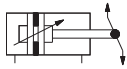

Z = Stroke

Ø	AG	BC	BG	DG	DP	DT	D1	E	EE	E1	FA	GG	HG	LA
16	14	M3	16	3	4	5,8	2	28	M5	30	9,9	3	5	3,2
20	17	M4	16	4	5	7,3	2	32	M5	34	12	4	7	4,2
25	22	M5	16	5	5	8	2	37	M5	39	15,6	5	9	4,5
32	28	M5	18	5	6	9	14	46	G1/8	47	19,8	5,2	11	5,3
40	33	M5	18	5	8	9	14	56	G1/8	57	23,3	5,2	15	5,3
50	42	M6	24	6	8	11	18	66	G1/8	67	29,7	6,2	19	6,5
63	50	M6	24	6	10	11	18	79	G1/8	80	35,4	6,2	25	6,5

Ø	LM	M	MM	PL	P1	RR	RT	SW	SW2	TG	WH	ZA	ZX
16	6	3,5	8	8	2	3,2	M4	7	-	18	5	37	48
20	8	4	10	8	2	4,2	M5	8	-	22	6	37	51
25	8	4	10	8	2	4,2	M5	8	-	26	6	39	53
32	10	4,5	12	7,5	2,5	5,2	M6	10	17	32,5	7	44	61
40	10	4,5	12	7,5	2,5	5,2	M6	10	19	42*	7	45	62
50	12	6,5	16	7,5	2,5	6,5	M8	13	24	50*	8	45	65
63	12	6,5	16	7,5	2,5	6,5	M8	13	24	62*	8	50	70

A) Pneumatic cushioning adjusting screw

B) Groove for sensor

* = Dimensional variations for end-caps with ISO inter-axes (RM series): Ø40 38 mm - Ø50 46,5 mm - Ø63 56,5 mm

Double acting non-rotating guided through piston rod RP Ø 16 ÷ 25

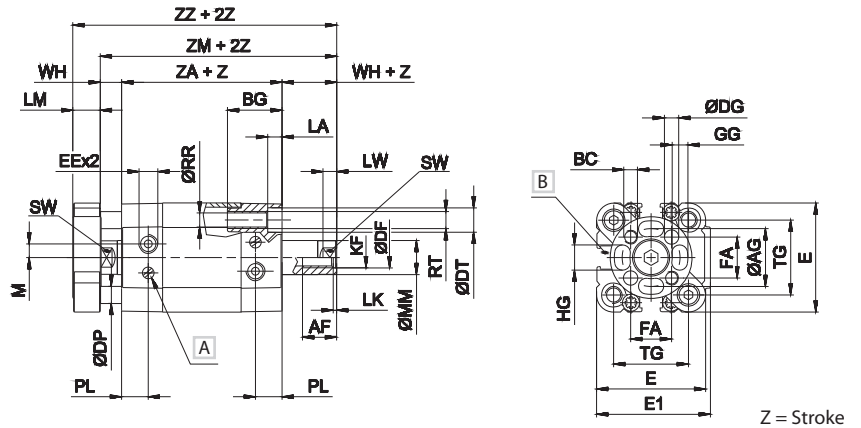
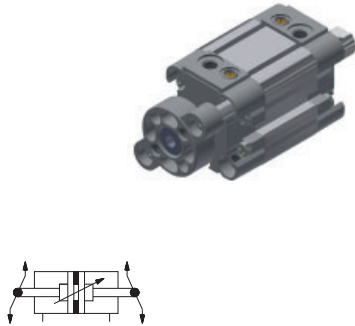

Double acting non-rotating guided through piston rod RP - RM Ø 32 ÷ 63

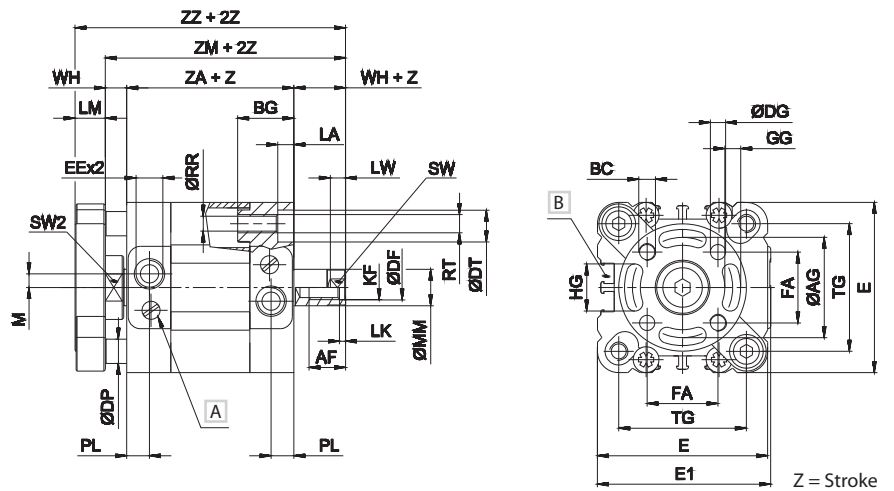
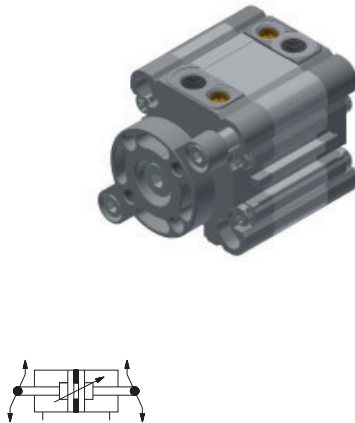

1
CYLINDERS

Ø	AF	AG	BC	BG	DF	DG	DP	DT	E	EE	E1	FA	GG	HG	KF	LA
16	8	14	M3	16	4,1	3	4	5,8	28	M5	30	9,9	3	5	M4	3,2
20	10	17	M4	16	6,1	4	5	7,3	32	M5	34	12	4	7	M6	4,2
25	10	22	M5	16	6,1	5	5	8	37	M5	39	15,6	5	9	M6	4,5
32	12	28	M5	18	8,2	5	6	9	46	G1/8	47	19,8	5,2	11	M8	5,3
40	12	33	M5	18	8,2	5	8	9	56	G1/8	57	23,3	5,2	15	M8	5,3
50	16	42	M6	24	10,2	6	8	11	66	G1/8	67	29,7	6,2	19	M10	6,5
63	16	50	M6	24	10,2	6	10	11	79	G1/8	80	35,4	6,2	25	M10	6,5

Ø	LK	LM	LW	M	MM	PL	RR	RT	SW	SW2	TG	WH	ZA	ZM	ZZ
16	1	6	4,5	3,5	8	8	3,2	M4	7	-	18	5	37	47	53
20	1	8	4,5	4	10	8	4,2	M5	8	-	22	6	37	49	57
25	1	8	4,5	4	10	8	4,2	M5	8	-	26	6	39	51	59
32	2	10	5	4,5	12	7,5	5,2	M6	10	17	32,5	7	44	58	68
40	2	10	5	4,5	12	7,5	5,2	M6	10	19	42*	7	45	59	69
50	2	12	6	6,5	16	7,5	6,5	M8	13	24	50*	8	45	61	73
63	2	12	6	6,5	16	7,5	6,5	M8	13	24	62*	8	50	66	78

A Pneumatic cushioning adjusting screw

B Groove for sensor

* = Dimensional variations for end-caps with ISO inter-axes (RM series): Ø40 38 mm - Ø50 46,5 mm - Ø63 56,5 mm

Tandem version

CODIFICATION KEY

R	P	1	A	0	2	0	0	4	0
1	2	3	4						

1 Series	2 Type	3 Bore (mm)	4 Stroke (mm)
RP = Ø16÷63 mm UNITOP Compact Cylinders RM = Ø16÷100 mm - ISO 21287 Compact Cylinders Magnetic series	1A = Double thrust tandem, stainless steel female piston rod 2A = Double thrust tandem, chromium-plated steel female piston rod 3A = Double thrust tandem, stainless steel male piston rod 4A = Double thrust tandem, chromium-plated steel male piston rod	016 = Ø16 032 = Ø32 063 = Ø63 020 = Ø20 040 = Ø40 080 = Ø80 (only RM) 025 = Ø25 050 = Ø50 100 = Ø100 (only RM)	Upon request

Z = Stroke

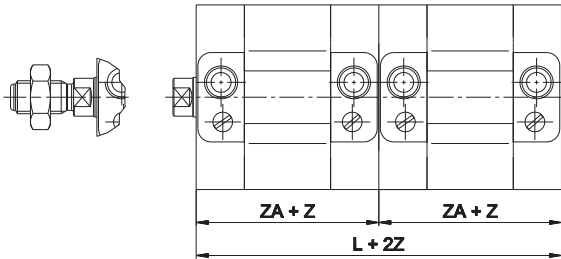

Ø	L	ZA
16	74	37
20	74	37
25	78	39
32	88	44
40	90	45
50	90	45
63	100	50
80	108	54
100	134	67

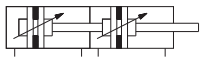

Tandem cylinders are constructed using two pistons coupled together which double the force in forward movement compared to the traditional cylinders of the same bore size

Two-position tandem version

CODIFICATION KEY

R	P	1	B	0	2	0	0	3	0	0	5	0
1	2	3	4									

1 Series	2 Type	3 Bore (mm)	4 Z1 stroke (mm)	5 Z2 stroke (mm)
RP = Ø16÷63 mm UNITOP Compact Cylinders RM = Ø16÷100 mm - ISO 21287 Compact Cylinders	1B = Two-position tandem, stainless steel female piston rod 2B = Two-position tandem, chromium-plated steel female piston rod 3B = Two-position tandem, stainless steel male piston rod 4B = Two-position tandem, chromium-plated steel male piston rod	016 = Ø16 063 = Ø63 020 = Ø20 080 = Ø80 (only RM) 025 = Ø25 100 = Ø100 (only RM) 032 = Ø32 040 = Ø40 050 = Ø50	Rear cylinder stroke on request	Front cylinder stroke on request

Z = Stroke

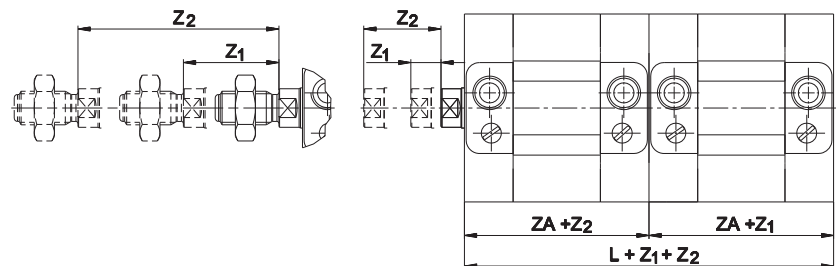

Ø	L	ZA
16	74	37
20	74	37
25	78	39
32	88	44
40	90	45
50	90	45
63	100	50
80	108	54
100	134	67

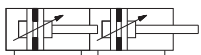

Two-position cylinders with two independent piston rods which allow to realize a double positioning in which the thrust forces are the same as those of a cylinder of the same bore size

For all other dimensions please refer to the standard version.
For other types of cylinders kindly contact our sales office

Subject to change

Three-position version (upon request)

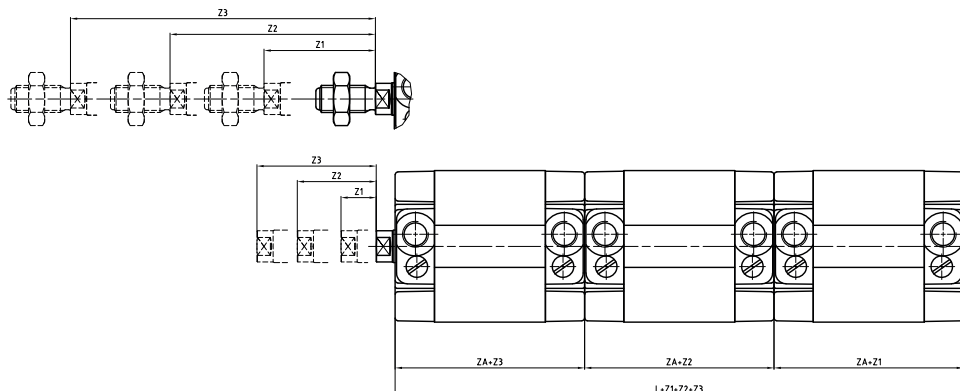

Z = Stroke

Ø	L	ZA
16	111	37
20	111	37
25	117	39
32	132	44
40	135	45
50	135	45
63	150	50
80	162	54
100	201	67

Opposed tandem version

CODIFICATION KEY

R	P	1	C	0	2	0	0	2	0	0	4	0
1	2	3	4	5								

1 Series	2 Type	3 Bore (mm)	4 Z1 stroke (mm)	5 Z2 stroke (mm)
RP = Ø16÷63 mm UNITOP Compact Cylinders	1C = Opposed tandem, stainless steel female piston rod	016 = Ø16 063 = Ø63	Upon request	Upon request
RM = Ø16÷100 mm - ISO 21287 Compact Cylinders	2C = Opposed tandem, chromium-plated steel female piston rod	020 = Ø20 080 = Ø80 (only RM)		
	3C = Opposed tandem, stainless steel male piston rod	025 = Ø25 100 = Ø100 (only RM)		
	4C = Opposed tandem, chromium-plated steel male piston rod	032 = Ø32		
		040 = Ø40		
		050 = Ø50		

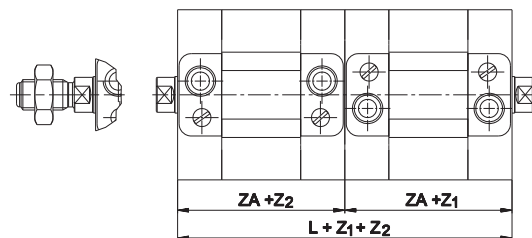

Z = Stroke

Ø	L	ZA
16	74	37
20	74	37
25	78	39
32	88	44
40	90	45
50	90	45
63	100	50
80	108	54
100	134	67



Type of cylinder characterized by the coupling of two cylinders and whose piston rods move in opposite directions. The values of the thrust force are the same as those of the traditional cylinders

With common piston rod tandem version (upon request)

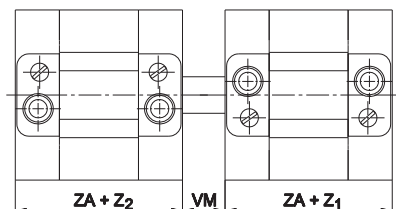

Z = Stroke

Ø	L	VM	ZA
16	74	10	37
20	74	10	37
25	78	12	39
32	88	14	44
40	90	14	45
50	90	16	45
63	100	16	50
80	108	20	54
100	134	20	67

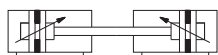

Two coupled cylinders with common piston rod. The values of the thrust force are the same as those of the traditional cylinders

For all other dimensions please refer to the standard version
For other types of cylinders kindly contact our sales office

Female rear hinge (ISO MP2) with pin

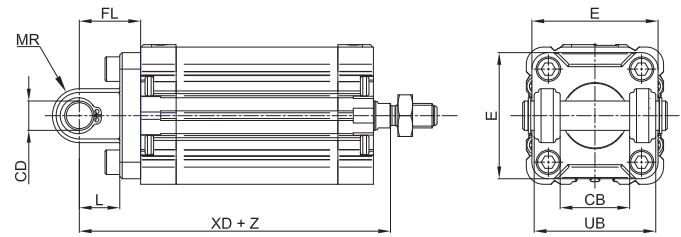
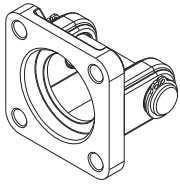

Material: Aluminium, zinc-plated steel pin

Z = Stroke

Ø	CB		C		E		FL		L		MR		UB		XD				Mass		Part no.		
	h14		h9				± 0,2		min		max		h14						g		RM ISO		
16	-	-	-	-	-	-	-	-	-	-	-	-	-	-	-	-	-	-	-	-	-	-	-
20	-	-	-	-	-	-	-	-	-	-	-	-	-	-	-	-	-	-	-	-	-	-	-
25	-	-	-	-	-	-	-	-	-	-	-	-	-	-	-	-	-	-	-	-	-	-	-
32	26	26	10	10	48	48	22	22	12	12	11	11	45	45	73	73	± 1,25	± 1,25	75	-	-	-	KF-10032A
40	28	28	12	12	54	54	25	25	15	16	13	12,5	52	52	77	77	± 1,25	± 1,25	110	156	RPF-10040A	KF-10040A	
50	32	32	12	12	65	65	27	27	15	16	13	12,5	60	60	80	80	± 1,25	± 1,25	150	200	RPF-10050A	KF-10050A	
63	40	40	16	16	75	75	32	32	20	21	17	15	70	70	90	90	± 1,6	± 1,6	270	362	RPF-10063A	KF-10063A	
80	50	-	20	-	95	-	36	-	20	-	17	-	90	-	100	-	-	± 1,6	-	420	-	-	KF-10080A
100	60	-	25	-	115	-	41	-	25	-	21	-	110	-	118	-	-	± 1,6	-	765	-	-	KF-10100A

Narrow female hinge with pin (DIN648K)

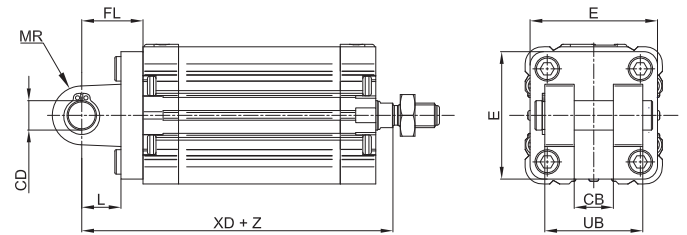
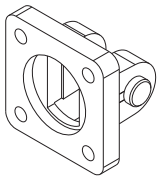

Material: Aluminium, zinc-plated steel pin

Z = Stroke

Ø	CB		C		E		FL		L		MR		UB		XD				Mass		Part no.		
	h14		h9				± 0,2		min		max		h14						g		RM ISO		
16	-	-	-	-	-	-	-	-	-	-	-	-	-	-	-	-	-	-	-	-	-	-	-
20	-	-	-	-	-	-	-	-	-	-	-	-	-	-	-	-	-	-	-	-	-	-	-
25	-	-	-	-	-	-	-	-	-	-	-	-	-	-	-	-	-	-	-	-	-	-	-
32	14	10	10	10	45	45	22	22	13	13	10	10	34	34	73	73	± 1,25	± 1,25	68	-	-	-	KF-10032AS
40	16	12	12	12	52	52	25	25	16	16	12	12	40	40	77	77	± 1,25	± 1,25	112	-	-	-	KF-10040AS
50	21	16	16	16	65	65	27	27	16	16	14	14	45	45	80	80	± 1,25	± 1,25	196	-	-	-	KF-10050AS
63	21	16	16	16	75	75	32	32	21	21	18	18	51	51	90	90	± 1,6	± 1,6	288	-	-	-	KF-10063AS
80	25	20	20	20	95	95	36	36	22	22	20	20	65	65	100	100	± 1,6	± 1,6	566	-	-	-	KF-10080AS
100	25	20	20	20	115	115	41	41	27	27	22	22	75	75	118	118	± 1,6	± 1,6	818	-	-	-	KF-10100AS

Rear hinge (ISO MP4)

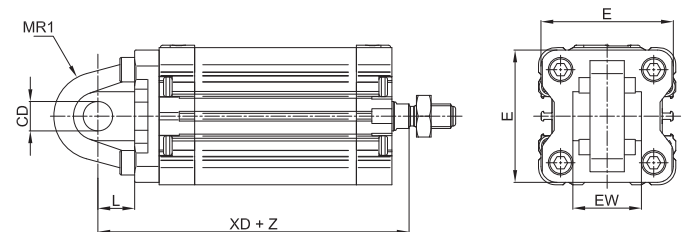
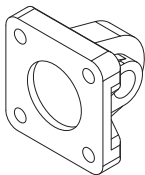

Material: Aluminium

Z = Stroke

Ø	CD		E		EW		L		MR1		XD		Mass		Part no.	
	h7		± 0,5		h14								g		RM ISO	
16	6	27	12	12	10	10	6	6	58	58	17	-	-	-	-	RPF-11016
20	8	34	16	16	14	14	8	8	63	63	21	-	-	-	-	RPF-11020
25	8	38	16	16	14	14	8	8	65	65	27	-	-	-	-	RPF-11025
32	10	48	26	26	12	12	15	15	73	73	80	-	-	-	-	KF-11032
40	12	54	28	28	15	15	18	18	77	77	100	-	-	-	-	KF-11040
50	12	65	32	32	15	15	20	20	80	80	170	-	-	-	-	KF-11050
63	16	75	40	40	20	20	23	23	89	89	250	-	-	-	-	KF-11063
80	16	95	50	50	20	20	27	27	210	210	420	-	-	-	-	KF-11080
100	20	115	60	60	25	25	29,5	29,5	230	230	660	-	-	-	-	KF-11100

Articulated rear male hinge (ISO MP4)

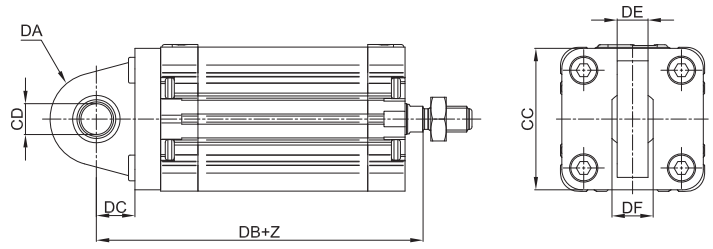
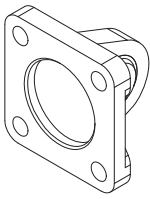

Material: Aluminium

Z = Stroke

Ø	CC	CD	DA	DB	DC	DE	DF	Mass g	Part no.	
									RP UNITOP	RM ISO
16	-	-	-	-	-	-	-	-	-	-
20	-	-	-	-	-	-	-	-	-	-
25	-	-	-	-	-	-	-	-	-	-
32	48	10	15	73	14	10,5	14	70	-	KF-110325
40	54	12	18	77	16,5	12	16	100	-	KF-110405
50	65	12	20	80	17,5	12	16	145	-	KF-110505
63	75	16	21	90	21,5	15	21	250	-	KF-110635
80	95	15	27	100	24	15	21	360	-	KF-110805
100	115	20	29,5	118	28	18	25	600	-	KF-111005

Front/rear flange

CYLINDERS

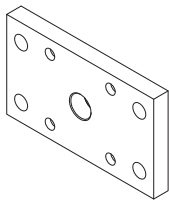

> Rear assembly

> Front assembly

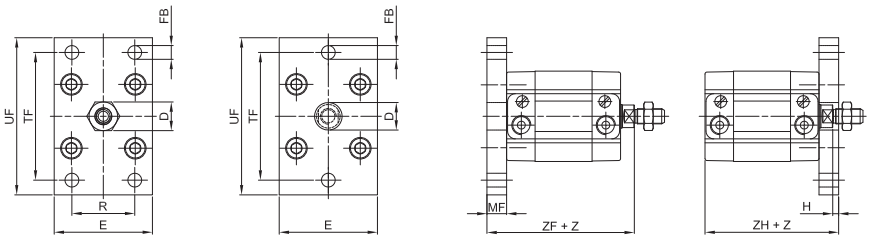

Material: Zinc-plated steel

Z = Stroke

Ø	Ø D Ø h11	E	Ø FB h13		H	MF		R Js14	TF Js14		UF	ZF	ZH	Mass g		Part no.									
														RP UNITOP	RM ISO	RP UNITOP	RM ISO								
16	10	-	29	-	4,5	-	5	-	10	-	-	-	43	-	55	-	47	-	100	-	RPF-12016	-			
20	12	-	36	-	6,6	-	4	-	10	-	-	-	55	-	70	-	53	-	47	-	160	-	RPF-12020	-	
25	12	-	40	-	6,6	-	4	-	10	-	-	-	60	-	76	-	55	-	49	-	200	-	RPF-12025	-	
32	14	30	50	45	7	7	3	3	10	10	32	32	65/64	64	80	80	61	61	54	54	260	200	KF-12032	-	
40	14	35	60	52	9	9	3	3	10	10	36	36	82/72	72	102	90	62	62	55	55	420	250	RPF-12040	KF-12040	
50	18	40	68	65	9	9	4	4	12	12	45	45	90	90	110	110	65	65	57	57	600	500	RPF-12050	KF-12050	
63	18	45	87	75	9	9	7	4	15	12	50	50	110	100	130	120	73	70	65	63	1200	650	RPF-12063	KF-12063	
80	-	45	-	95	-	12	-	8	-	16	-	63	-	126	-	150	-	80	-	70	-	1500	-	KF-12080	-
100	-	55	-	115	-	14	-	8	-	16	-	75	-	150	-	170	-	93	-	83	-	2200	-	KF-12100	-

Angle bracket

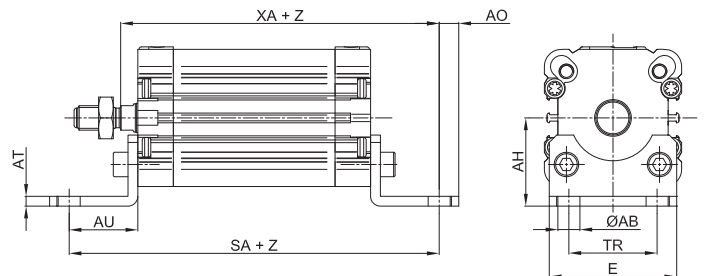
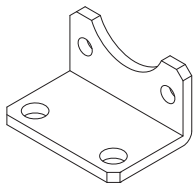

Material: Zinc-plated steel

Z = Stroke

Ø	Ø AB Ø h13	AH Js15		AO	AT	AU		E	SA	TR	XA	Mass g		Part no.									
												RP UNITOP	RM ISO										
16	5,5	-	22	-	4,5	-	3	-	13	-	30	-	63	-	18	-	55	-	20	-	RPF-13016	-	
20	6,6	-	27	-	6	-	4	-	16	-	36	-	69	-	22	-	59	-	30	-	RPF-13020	-	
25	6,6	-	30	-	6	-	4	-	16	-	40	-	71	-	26	-	61	-	40	-	RPF-13025	-	
32	6,6	7	32,25	32	8	6	5	4	18	24	50	45	80	92	32	32	69	75	70	-	KF-13032	-	
40	6,6	9	42,5	36	8	8	5	4	20	28	60	52	85	101	42	36	72	80	100	-	RPF-13040	KF-13040	
50	9	9	47	45	8	10	6	5	24	32	68	64	93	109	50	45	77	85	150	-	RPF-13050	KF-13050	
63	9	9	59,5	50	12	12	6	5	27	32	84	74	104	114	62	50	85	93	250	-	RPF-13063	KF-13063	
80	-	12	-	63	-	15	-	6	-	41	-	94	-	136	-	63	-	215	-	400	-	KF-13080	-
100	-	14	-	71	-	20	-	6	-	41	-	114	-	149	-	75	-	230	-	600	-	KF-13100	-

ISO intermediate hinge

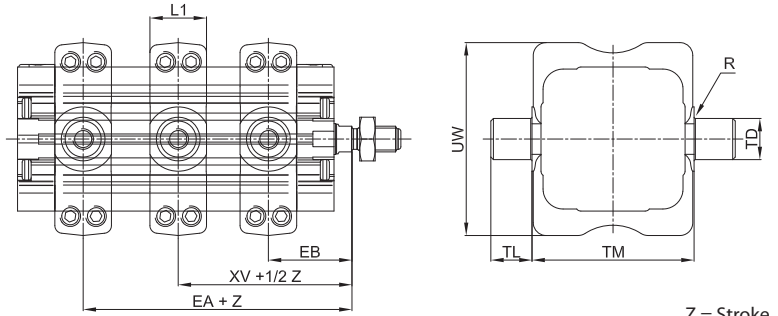
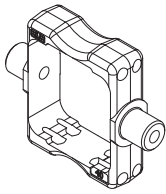

Material: Zinc-plated steel

Z = Stroke

Ø	EA	EB	L1	R	TD	TL	TM	UW	XV		Mass	Part no.		
	(MAX)	(min)	(MAX)	(MAX)	(e9)	(h14)	(h14)	(MAX)				g	RP UNITOP	RM ISO
16	-	-	-	-	-	-	-	-	-	-	-	-	-	-
20	-	-	-	-	-	-	-	-	-	-	-	-	-	-
25	-	-	-	-	-	-	-	-	-	-	-	-	-	-
32	24	34	22	0,5	12	12	50	65	29	± 2	130	-	KDF-14032	-
40	25	34	22	0,5	16	16	63	75	29,5	± 2	240	-	RPF-14040	-
50	26	35	22	1	16	16	75	95	30,5	± 2	320	-	RPF-14050	-
63	27	38	28	1	20	20	90	105	32,5	± 2	470	-	RPF-14063	-
80	- 37,5	- 40	- 27,5	- 1	- 20	- 20	- 108	- 130	- 37	- ± 2	- 800	-	-	KDF-14080
100	- 45,5	- 48	- 33	- 1	- 25	- 25	- 130	- 145	- 43,5	- ± 2	- 1500	-	-	KDF-14100

Front/rear hinge with floating pin

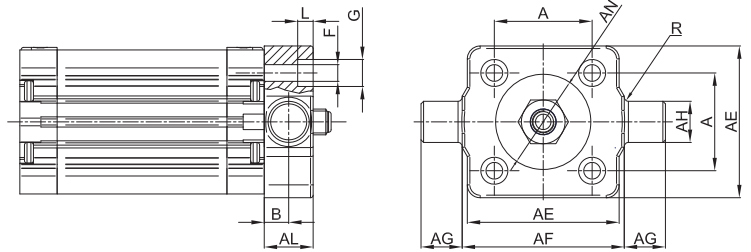
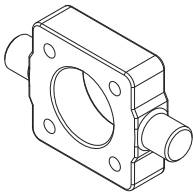

Material: Zinc-plated steel

Ø	AE	AL	AH	AG	AF	AN	A	B	F	G	L	R	Mass	Part no.
	(MAX)	(MAX)	e9	h14	h14	h11	± 0,2	± 0,2/0	h13	h13	± 0,5/0	0/± 0,3		
16	-	-	-	-	-	-	-	-	-	-	-	-	-	-
20	-	-	-	-	-	-	-	-	-	-	-	-	-	-
25	-	-	-	-	-	-	-	-	-	-	-	-	-	-
32	46	14	12	12	50	30	32,5	6,5	6,5	-	6	1	137	KF-14032AP
40	59	19	16	16	63	35	38	9	6,5	10,5	6	1,6	385	KF-14040AP
50	69	19	16	16	75	40	46,5	9	8,5	13,5	8	1,6	513	KF-14050AP
63	84	24	20	20	90	45	56,5	11,5	8,5	13,5	8	1,6	1041	KF-14063AP
80	102	24	20	20	110	45	72	11,5	10,5	16,5	10	1,6	1567	KF-14080AP
100	125	29	25	25	132	55	89	14	10,5	16,5	10	2	3000	KF-14100AP

Counter hinge 90°

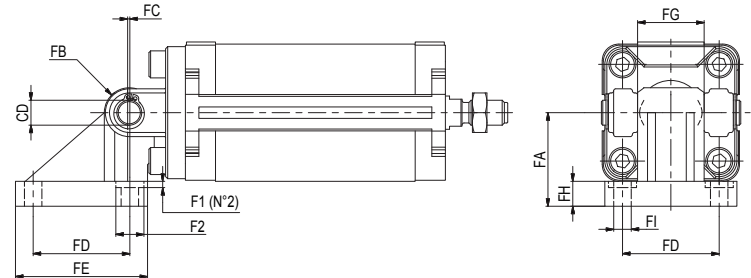
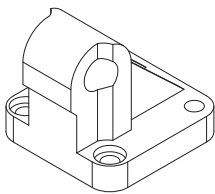

Material: Aluminium

Ø	CD	FA	FB	FC	FD	FE	FG	FH	FI	F1	F2	Mass	Part no.	
	h9	J515					- 0,2/- 0,6						g	RP UNITOP
16	-	-	-	-	-	-	-	-	-	-	-	-	-	-
20	-	-	-	-	-	-	-	-	-	-	-	-	-	-
25	-	-	-	-	-	-	-	-	-	-	-	-	-	-
32	10	32	10	1,2	32,5	46,5	26	9	6,4	5,5	10,5	90	-	KF-19032
40	12	36	12	2,6	38	51,5	28	9	6,6	5,5	10,5	120	-	KF-19040
50	12	45	12	0,3	46,5	63,5	32	9	8,4	5	13,5	200	-	KF-19050
63	16	50	16	3,3	56,5	73,5	40	10,5	8,4	5	13,5	320	-	KF-19063
80	- 16	- 63	- 16	- 1,0	- 72	- 93	- 50	- 12	- 10,5	- 6	- 16,5	- 580	-	KF-19080
100	- 20	- 73	- 20	- 2,5	- 89	- 113	- 60	- 13	- 10,5	- 6	- 16,5	- 910	-	KF-19100

Counter hinge 90° (CETOP)

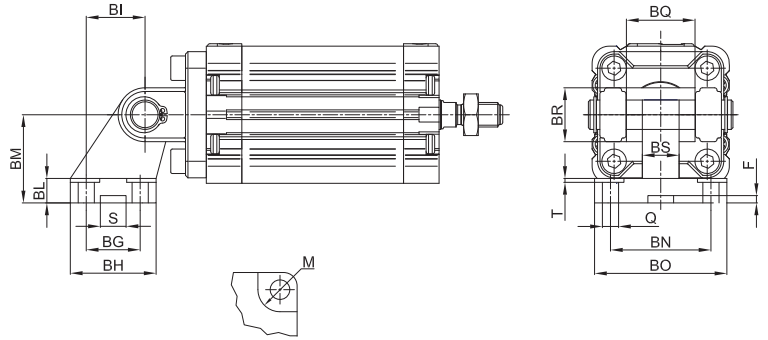
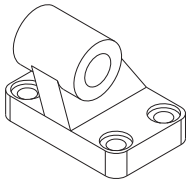

Material: Aluminium

Ø	Q	M	BG	BH	BI	BL	BM	BN	BO	BS	BR	T	G	S	F	BQ	Mass	Part no.
	h13	h13	Js14	Max	Js14		Js15	Js14	Max	Max	Max	Max	h9	+ 0,5/0	+ 0,5/0			
16	-	-	-	-	-	-	-	-	-	-	-	-	-	-	-	-	-	-
20	-	-	-	-	-	-	-	-	-	-	-	-	-	-	-	-	-	-
25	-	-	-	-	-	-	-	-	-	-	-	-	-	-	-	-	-	-
32	6,6	11	18	31	21	8	32	38	51	10	20	1,6	10	10,5	3	-	56	KF-19032CTA
40	6,6	11	22	35	24	10	36	41	54	15	22	1,6	12	10,5	3	-	139	KF-19040CTA
50	9	15	30	45	33	12	45	50	65	16	26	1,6	12	10,5	3	0,2	142	KF-19050CTA
63	9	15	35	50	37	14	50	52	67	16	30	1,6	16	10,5	3	0,6	200	KF-19063CTA
80	11	18	40	60	47	14	63	66	86	20	30	2,5	16	10,5	3	-	321	KF-19080CTA
100	11	18	50	70	55	17	71	76	96	20	38	2,5	20	10,5	3	-	656	KF-19100CTA

Counter hinge 90° (CNOMO)

1
CYLINDERS

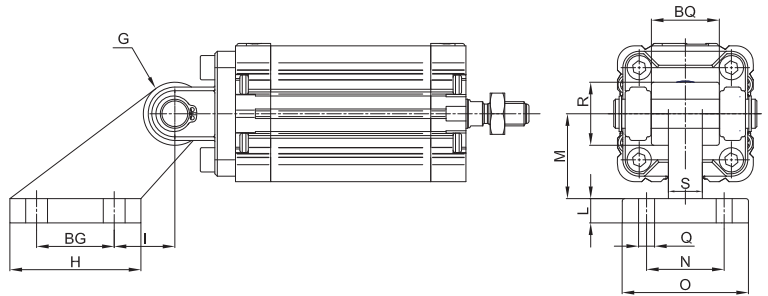
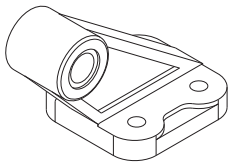

Material: Zinc-plated steel

Ø	Q	BG	H	I	L	M	N	O	S	R	BQ	G	Mass	Part no.
	h13	± 0,2		± 0,2		± 0,2	± 0,2			Max	± 0,2/± 0,1	h9		
16	-	-	-	-	-	-	-	-	-	-	-	-	-	-
20	-	-	-	-	-	-	-	-	-	-	-	-	-	-
25	-	-	-	-	-	-	-	-	-	-	-	-	-	-
32	7	20	37	18	8	24	25	41	9	19,5	25	8	58	KF-19032CN
40	9	32	54	25	10	35	32	52	14	26	32	12	144	KF-19040050CN
50	9	32	54	25	10	35	32	52	14	26	32	12	144	KF-19040050CN
63	11	50	75	32	13	50	40	63	14	32	46	16	300	KF-19063080CN
80	11	50	75	32	13	50	40	63	14	32	46	16	300	KF-19063080CN
100	14	70	103	40	17	73	50	80	22	42	56	20	694	KF-19100125CN

Counter hinge with articulated team

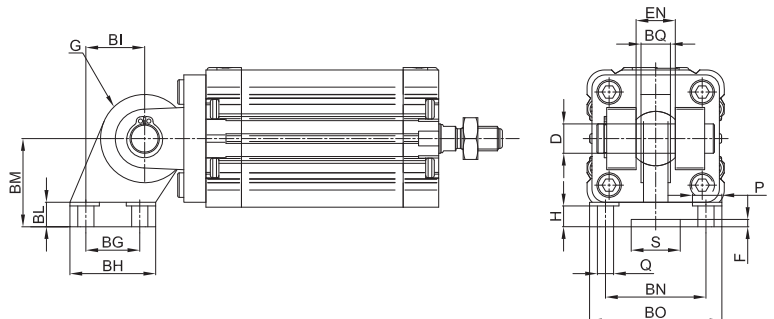
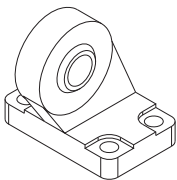

Material: Zinc-plated steel

Ø	Q	P	BG	BH	BI	BL	BM	BN	BO	EN	ER	BQ	D	H	S	F	Mass	Part no.
	h13	h13	Js14	Max	Js15		Js15	Js14	Max	0/- 0,1	Max	Max	h7	+ 0,5/0	h13			
16	-	-	-	-	-	-	-	-	-	-	-	-	-	-	-	-	-	-
20	-	-	-	-	-	-	-	-	-	-	-	-	-	-	-	-	-	-
25	-	-	-	-	-	-	-	-	-	-	-	-	-	-	-	-	-	-
32	6,6	11	18	31	21	10	32	38	51	14	15	10,5	10	8,5	20	3	58	KF-19032SC
40	6,6	11	22	35	24	10	36	41	54	16	18	12	12	8,8	20	3	144	KF-19040SC
50	9	15	30	45	33	12	45	50	65	21	20	15	16	10,5	20	3	144	KF-19050SC
63	9	15	35	50	37	12	50	52	67	21	23	15	16	10,5	20	3	300	KF-19063SC
80	11	18	40	60	47	14	63	66	86	25	27	18	20	11,5	20	3	300	KF-19080SC
100	11	18	50	70	55	15	71	76	96	25	30	18	20	12,5	20	3	694	KF-19100SC

Hinge support

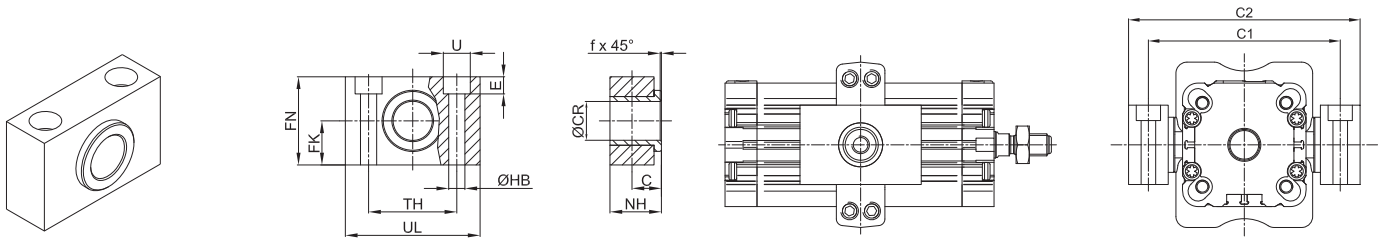

Material: Anodized aluminium and brass bushing

Z = Stroke

Ø	C	CR	FK	FN	HB	NH	TH	UL	U	E	F	C1	C2	Mass	Part no.
		F7	± 0,1				± 0,1			± 0,5				g	
32	10,2	12	15	30	6,6	18	32	46	11	7	1	71	86	110	KF-41032
40-50	12	16	18	36	9	21	36	55	15	9	1,6	Ø40 Ø50 87 99	Ø40 Ø50 105 117	200	KF-41040050
63-80	13	20	20	40	11	23	42	65	18	11	1,6	Ø63 Ø80 116 136	Ø63 Ø80 136 156	267	KF-41063080
100-125	16	25	25	50	14	28,5	50	75	20	13	2	Ø100 Ø125 164 192	Ø100 Ø125 189 217	485	KF-41100125

Pin with 2 circlips

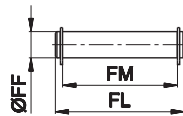

Material: Zinc-plated steel

Cylinder Ø	FF	FL	FM	Mass	Part no.
	f8			g	
32	10	53	46	30	KF-18032
40	12	61,3	53	50	KF-18040
50	12	69	61	50	KF-18050
63	16	80,5	71	120	KF-18063
80	16	100,5	91	150	KF-18080
100	20	122,5	111	290	KF-18100

> Fixing screws

Cylindrical screw
UNI 5931 suitable for
mounting elements
Series RPF-12.../RPF-13.../RPF-11...

Cylinder Ø	Screw	Part no.
16	M4x18	AZ4-VN0418
20 - 25	M5x18	AZ4-VN0518
32 - 40	M6x20	AZ4-VN0620
50 - 63	M8x25	AZ4-VN0825
80	M10x30	AZ4-VN1030
100	M10x30	AZ4-VN1030

Cylindrical screw
UNI 5931 suitable for
mounting elements
Series KF-10032/RPF-10...

Cylinder Ø	Screw	Part no.
32 - 40	M6x25	AZ4-VN0625
50 - 63	M8x30	AZ4-VN0830
80	M10x30	AZ4-VN1030
100	M10x30	AZ4-VN1030

Pin for narrow hinge

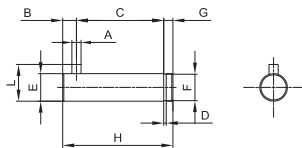

Material: Zinc-plated steel

Ø	A	C	D	E	F	G	H	L	B	Part no.
	H12	+0,5/ +0,3	H13	F7	H11			0 / -0,5		
32	3	32,5	1,1	10	9,6	4	41	14	4,5	KF-18032S
40	4	38	1,1	12	11,5	4	48	16	6	KF-18040S
50	4	43	1,1	16	15,2	5	54	20	6	KF-18050S
63	4	49	1,1	16	15,2	5	60	20	6	KF-18063S
80	4	63	1,3	20	19	6	75	24	6	KF-18080S
100	4	73	1,3	20	19	6	85	24	6	KF-18100S

Female fork with clips

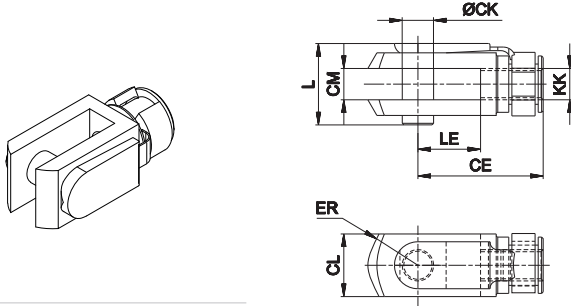

Material: Zinc-plated steel

Cylinder Ø	CE	CK	CL	CM	ER	KK	L	LE	Mass g	Part no.
16	24	6	12	6	7	M6x1	16	12	19	MF-15012
20 - 25	32	8	16	8	10	M8x1,25	22	16	46	MF-15020
32 - 40	40	10	20	10	16	M10x1,25	26	20	90	KF-15032
50 - 63	48	12	24	12	19	M12x1,25	32	24	150	KF-15040
80 - 100	80	20	40	20	32	M16x1,5	50	40	670	KF-15050

Fork with pin for piston rod according to ISO 8140 standard

Articulated self-lubricating fork

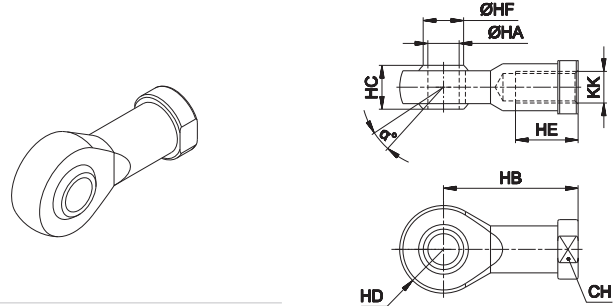

Material: Zinc-plated steel

Cylinder Ø	α°	CH	KK	HA	HB	HC	HD	HE	HF	Mass g	Part no.	
16	13	11	M6x1	H7	6	30	9	10	12	9	26	MF-17012
20 - 25	13	14	M8x1,25	8	36	12	12	16	10,4	46	MF-17020	
32 - 40	13	17	M10x1,25	10	43	14	14	20	12,9	76	KF-17032	
50 - 63	13	19	M12x1,25	12	50	16	16	22	15,4	110	KF-17040	
80 - 100	14	30	M16 x 1,5	20	77	25	25	33	24,3	400	KF-17050	

Fork with axially mounted articulated pin

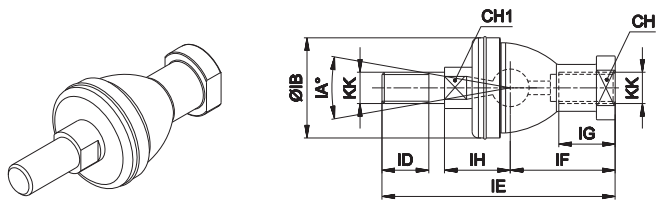

Material: Zinc-plated steel

Cylinder Ø	CH	CH1	IA°	KK	IH	IB	ID	IE	IF	IG	Mass g	Part no.
16	11	8	30	M6x1	12,2	22	11	55,2	28	15	40	MF-22016
20 - 25	14	10	30	M8x1,25	16	28	12	65	32	16	75	MF-22020
32 - 40	17	11	30	M10x1,25	19,5	32	15	74,5	35	18	120	KF-22025
50 - 63	19	17	30	M12x1,25	22	36	17	84	40	20	185	KF-22040
80 - 100	30	24	15	M16x1,5	31,5	58	25	133	63	38	570	KF-22050

Fork with angle mounted articulated pin

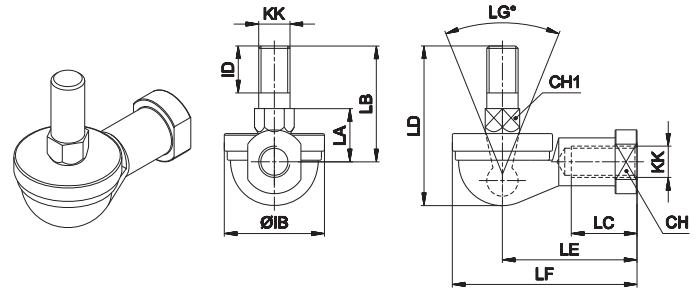

Material: Zinc-plated steel

Cylinder Ø	CH	CH1	LG°	KK	IB	ID	LA	LB	LC	LD	LE	LF	Mass g	Part no.
16	11	8	50	M6x1	22	11	11	26	14	35,5	30	40	37	MF-23012
20 - 25	14	10	50	M8x1,25	28	12	14	31	17	42,5	36	48	67	MF-23020
32 - 40	17	11	50	M10x1,25	32	15	17	37	21	50,5	43	57	110	KF-23025
50 - 63	19	17	50	M12x1,25	36	17	19	42	27	57,5	50	66	165	KF-23040
80 - 100	30	24	32	M16x1,5	58	25	27	68	40	90	77	99	540	KF-23050

1
CYLINDERS

Floating joint

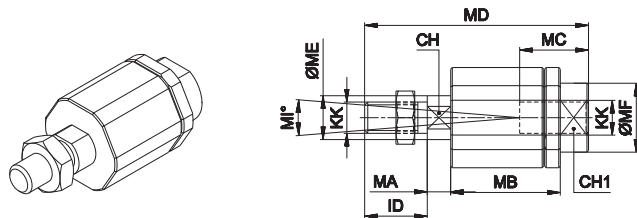

Material: Zinc-plated steel

Cylinder Ø	CH	CH1	ID	KK	MA	MB	MC	MD	ME	MF	MG	MH	MI°	Mass g	Part no.
16	5	7	11	M6x1	2,5	17,5	12,5	35	6	8,5	13	14,5	6	55	MF-24012
20 - 25	7	11	21	M8x1,25	5	26	16	57	8	12,5	17	19	8	60	MF-24020
32 - 40	12	19	71	M10x1,25	5	35	20	71	14	22	30	32	8	220	KF-24032
50 - 63	12	19	75	M12x1,25	5	35	20	75	14	22	30	32	8	230	KF-24040
80 - 100	20	30	119	M20x1,5	8	54	40	119	22	32	41	45	6	700	KF-24080

Piston rod locknut (zinc-plated steel)



Material: Zinc-plated steel

Cylinder Ø	KK	KV	KW	Mass g	Part no.
16	M6x1	10	4	1,6	MF-16012
20 - 25	M8x1,25	13	5	3,4	MF-16020
32 - 40	M10x1,25	17	6	5	KF-16032
50 - 63	M12x1,25	19	7	10	KF-16040
80 - 100	M20x1,5	30	9	30	KF-16080

Flange for female piston rod (only for RP series)

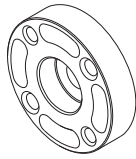

Material: Aluminium

Cylinder Ø	Mass g	Part no.
16	0,007	RPF-28016
20	0,018	RPF-28020
25	0,020	RPF-28025
32	0,024	RPF-28032
40	0,035	RPF-28040
50	0,057	RPF-28050
63	0,094	RPF-28063

Centering adaptor ring

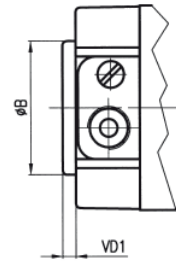

Material: Aluminium

Ø	ØB	VD1	Part no.	
			RP UNITOP	RM ISO
16	-	-	-	-
20	-	-	-	-
25	-	-	-	-
32	30	3	RSF-09032	
40	35	3	RSF-09040	
50	40	3	RSF-09050	
63	45	3	RSF-09063	
80	45	4	-	RSF-09080
100	55	4	-	RSF-09100